

# Dealer's Manual

ROAD	MTB	Trekking
City Touring/ Comfort Bike	URBAN SPORT	E-BIKE

# SHIMANO STEPS

## E8000 Series

SC-E8000  
SC-E6010  
SW-E8000-L  
SW-M9050-R  
SW-M8050-R  
SW-E6010  
RD-M9050  
RD-M8050  
FC-E8000  
FC-E8050  
FC-M8050  
SM-CRE80  
SM-CRE80-B  
SM-CDE80  
DU-E8000  
SM-DUE10  
SM-DUE11  
SM-DUE80-A  
SM-DUE80-B  
BT-E8010  
BT-E8020  
BM-E8010  
BM-E8020

TL-FC39  
RT-EM800  
RT-EM900

# CONTENTS

---

IMPORTANT NOTICE .....	iv
TO ENSURE SAFETY .....	v

## **Chapter1 LIST OF TOOLS TO BE USED 1-1**

LIST OF TOOLS TO BE USED .....	1-2
--------------------------------	-----

## **Chapter2 INSTALLATION 2-1**

INSTALLATION.....	2-2
Names of parts.....	2-2
Product specifications.....	2-3
Installing the cycle computer.....	2-4
Installing and removing the cycle computer (SC-E6010).....	2-6
Adjusting the angle of the cycle computer (SC-E6010).....	2-6
Installing the assist switch.....	2-7
Using the cable band to attach the assist switch to the handlebar .....	2-8
Installing the assist switch.....	2-9
Connecting the electric wire.....	2-10
Installing the battery mount .....	2-13
Installing / removing the battery.....	2-22
Installing the speed sensor .....	2-26
Mounting the magnet .....	2-27

## **Chapter3 INSTALLING AND WIRING THE DRIVE UNIT 3-1**

INSTALLING AND WIRING THE DRIVE UNIT .....	3-2
Installing the drive unit.....	3-2
Drive unit wiring diagram .....	3-3
Connecting the power cord.....	3-4
Connecting switches and the drive unit to the cycle computer (SC-E8000) .....	3-5
Connecting the assist switch and drive unit to the cycle computer (SC-E6010) .....	3-5
Connecting the speed sensor to the drive unit .....	3-6
Connecting the light cable to the drive unit .....	3-7
Installing the crank and front chainring.....	3-8

**Chapter4 CHARGING THE BATTERY 4-1**

**CHARGING THE BATTERY .....4-2**  
Proper use of the battery.....4-2  
Charging the battery.....4-3  
About the charger LED lamp.....4-5  
About the battery LED lamps .....4-5  
Turning the power ON / OFF.....4-8

**Chapter5 HOW TO OPERATE 5-1**

**HOW TO OPERATE..... 5-2**  
About the functions of the assist switches and shift switches.....5-2  
Cycle computer display and setting .....5-3  
Battery level indicator.....5-4  
Assist mode.....5-5  
Switching between displayed traveling data .....5-7  
About the setting menus.....5-9  
Error messages on the cycle computer.....5-27

**Chapter6 CONNECTION AND COMMUNICATION WITH DEVICES 6-1**

**CONNECTION AND COMMUNICATION WITH DEVICES .....6-2**  
About wireless functions .....6-2  
2.4 GHz digital wireless system.....6-3  
Drive unit setting backup function for the cycle computer .....6-3  
Settings customizable in E-TUBE PROJECT.....6-4  
Connecting to the PC.....6-6

**Chapter7 MAINTENANCE 7-1**

**MAINTENANCE ..... 7-2**  
Replacing the clamp band .....7-2  
Replacing the front chainring .....7-3  
Replacing the guide of the chain device .....7-4

## IMPORTANT NOTICE

- **This dealer's manual is intended primarily for use by professional bicycle mechanics.**

Users who are not professionally trained for bicycle assembly should not attempt to install the components themselves using the dealer's manuals. If any part of the information on the manual is unclear to you, do not proceed with the installation. Instead, contact your place of purchase or a local bicycle dealer for their assistance.

- Make sure to read all instruction manuals included with the product.
- Do not disassemble or modify the product other than as stated in the information contained in this dealer's manual.
- All dealer's manuals and instruction manuals can be viewed on-line on our website (<http://si.shimano.com>).
- Please observe the appropriate rules and regulations of the country, state or region in which you conduct your business as a dealer.
- The Bluetooth® word mark and logos are registered trademarks owned by the Bluetooth SIG, Inc. and any use of such marks by SHIMANO INC. is under license. Other trademarks and trade names are those of their respective owners.

**For safety, be sure to read this dealer's manual thoroughly before use, and follow it for correct use.**

The following instructions must be observed at all times in order to prevent personal injury and physical damage to equipment and surroundings. The instructions are classified according to the degree of danger or damage which may occur if the product is used incorrectly.

 **DANGER**

Failure to follow the instructions will result in death or serious injury.

 **WARNING**

Failure to follow the instructions could result in death or serious injury.

 **CAUTION**

Failure to follow the instructions could cause personal injury or physical damage to equipment and surroundings.

## TO ENSURE SAFETY

### DANGER

#### Be sure to also inform users of the following:

##### ■ Handling the battery

- Do not deform, modify, disassemble or apply solder directly to the battery. Doing so may cause leakage, overheating, bursting, or ignition of the battery.
- Do not leave the battery near sources of heat such as heaters. Do not heat the battery or throw it into a fire. Doing so may cause bursting or ignition of the battery.
- Do not subject the battery to strong shocks or throw it. If this is not observed, overheating, bursting, or fire may occur.
- Do not place the battery into fresh water or sea water, and do not allow the battery terminals to get wet. Doing so may cause overheating, bursting, or ignition of the battery.
- Use the Shimano specified charger and observe the specified charging conditions when charging the specified battery. Not doing so may cause overheating, bursting, or ignition of the battery.

### WARNING

- Be sure to follow the instructions provided in the manuals when installing the product.  
*It is recommended that you use only genuine Shimano parts. If parts such as bolts and nuts become loose or damaged, the bicycle may suddenly fall over, which may cause serious injury. In addition, if adjustments are not carried out correctly, problems may occur, and the bicycle may suddenly fall over, which may cause serious injury.*
-  Be sure to wear safety glasses or goggles to protect your eyes while performing maintenance tasks such as replacing parts.
- For information on products not explained in this manual, refer to the manuals provided with each product.
- After reading the dealer's manual thoroughly, keep it in a safe place for later reference.

#### Be sure to also inform users of the following:

- Be careful not to let yourself be distracted by the cycle computer display while riding the bicycle. Otherwise, you may fall off the bicycle.
- Before riding, check that the wheels are secured. Otherwise, you may fall off the bicycle and be seriously injured.
- Be sufficiently familiar with how to start the power assisted bicycle before riding on busy streets. Otherwise, you may start the bicycle abruptly and have an accident.
- Make sure that the light is on during night riding.
- Do not disassemble the product. Disassembling it may cause injury to persons.
- When charging the battery while it is installed on the bicycle, do not move the bicycle. The battery charger's power plug may not be completely inserted into the outlet, which may lead to fire.

### ■ Lithium Ion Battery

- If any liquid leaking from the battery gets into your eyes, immediately wash the affected area thoroughly with clean water such as tap water without rubbing your eyes, and seek medical advice immediately. If this is not done, the battery liquid may damage your eyes.
- Do not recharge the battery in very humid places or the outdoors. If this is not observed, electric shocks may result.
- Do not insert or remove the plug while it is wet. If this is not observed, electric shocks may result. If there is water leaking out of the plug, dry it thoroughly before inserting it.
- If the battery does not become fully charged after 6 hours of charging, immediately unplug the battery from the outlet and contact the place of purchase. Not doing so may cause overheating, bursting, or ignition of the battery.
- Do not use the battery if it has any noticeable scratches or other external damage. Doing so may cause bursting, overheating or problems with operation.
- The operating temperature ranges for the battery are given below. Do not use the battery in temperatures outside these ranges. If the battery is used or stored in temperatures outside these ranges, fire, injury or problems with operation may occur.
  1. During discharge:  $-10\text{ }^{\circ}\text{C}$  -  $50\text{ }^{\circ}\text{C}$
  2. During charging:  $0\text{ }^{\circ}\text{C}$  -  $40\text{ }^{\circ}\text{C}$

### ■ Items related to installation to and maintenance of the bicycle

- Be sure to remove the battery and charger before wiring or attaching parts to the bicycle. Otherwise, an electric shock may result.
- Be sure to follow the instructions provided in the manuals when installing the product. It is recommended that you use only genuine Shimano parts. If bolts and nuts become loose or the product is damaged, the bicycle may suddenly fall over, resulting in a serious injury.
- Maintenance interval depends on the usage and riding circumstances. Clean regularly the chain with an appropriate chain cleaner. Never use alkali based or acid based solvents such as rust cleaners. If those solvent be used chain might break and cause serious injury.



### Be sure to also inform users of the following:

- Observe the instructions in the user's manual for the bicycle, in order to ride safely.
- Periodically check the battery charger and adapter, particularly the cord, plug, and case, for any damage. If the charger or adapter is broken, do not use it until it has been repaired.
- Use the product under the direction of a safety supervisor or the directions for use. Do not allow physically, sensory, or mentally impaired persons, inexperienced persons, or persons with no required knowledge including children to use this instrument.
- Do not allow children to play near the product.
- If any malfunction or trouble occurs, consult the dealer nearest you.
- Never modify the system. This may cause a malfunction in the system.

### ■ Lithium Ion Battery

- Do not leave the battery in a place exposed to direct sunlight, inside a vehicle on a hot day, or other hot places. This may result in battery leakage.
- If any leaked fluid gets on your skin or clothes, wash it off immediately with clean water. Otherwise, the leaked fluid may damage your skin.
- Store the battery in a safe place out of the reach of infants and pets.

**NOTE****Be sure to also inform users of the following:**

- Be sure to attach dummy plugs to any unused ports.
- For installation and adjustment of the product, consult a dealer.
- The units are designed to be fully waterproof to withstand wet weather riding conditions. However, do not deliberately place them into water.
- Do not clean the bicycle with a high-pressure washer. If water gets into any of the components, operating problems or rusting may result.
- Handle the components carefully, and avoid subjecting them to any strong shocks.
- Do not place the bicycle upside down. Doing so may damage the cycle computer or shift switch.
- Although the bicycle still functions as a normal bicycle even when the battery is removed, the light does not turn on if it is connected to the electric power system. Be aware that using the bicycle under these conditions will be considered non-observance of the road traffic laws in Germany.
- When carrying the bicycle in a car, remove the battery from the bicycle and place it on a stable surface in the car.
- Before connecting the battery, make sure that there is no buildup of water or dirt in the connector where the battery will be connected.
- When charging the battery while it is mounted on the bicycle, be careful of the following:
  - When charging, make sure there is no water on the charging port or the charger plug.
  - Check that the battery mount is locked before charging.
  - Do not remove the battery from the battery mount while charging.
  - Do not ride the bicycle with the battery charger mounted on.
  - Close the charging port cap when not charging.
  - Stabilize the bicycle to ensure that it does not collapse during charging.
- The use of a genuine Shimano battery is recommended. If using a battery from another manufacturer, make sure to carefully read the instruction manual for the battery before use.
- Some of the important information in this dealer's manual can also be found on the device labels.
- The number found on the battery key is necessary when purchasing spare keys. Store it carefully.
- Use a damp cloth, with the water well wrung out, when cleaning the battery and plastic cover.
- If you have any questions about the use and maintenance of the product, consult the dealer where you made the purchase.
- Contact the place of purchase for updates of the component software. The most up-to-date information is available on the Shimano website. For details, refer to the "CONNECTION AND COMMUNICATION WITH DEVICES" section.
- Products are not guaranteed against natural wear and deterioration from normal use and aging.
- For maximum performance we highly recommend Shimano lubricants and maintenance products.

**■ Connection and communication with PC**

A PC linkage device can be used to connect a PC to the bicycle (system or components), and E-TUBE PROJECT can be used to carry out tasks such as customizing single components or the whole system and updating firmware.

- PC linkage device: SM-PCE1
- E-TUBE PROJECT: PC application
- Firmware: software inside each component

**■ Connection and communication with smartphone or tablet**

It is possible to customize single components or the system, and update firmware, using E-TUBE PROJECT for smartphones/tablets after connecting the bicycle (system or components) to a smartphone or tablet via Bluetooth LE.

- E-TUBE PROJECT: app for smartphones/tablets
- Firmware: software inside each component

■ **Lithium Ion Battery**



**Disposal information for countries outside the European Union**

This symbol is only valid within the European Union.

Follow local regulations when disposing of used batteries. If you are not sure, consult the place of purchase or a bicycle dealer.

■ **Items related to installation to and maintenance of the bicycle**



- Do not use thinner or other solvents to clean any of the components. Such substances may damage the surfaces.
- You should periodically wash the chainrings in a neutral detergent. In addition, cleaning the chain with neutral detergent and lubricating it can be an effective way of extending the useful life of the chainrings and the chain.

















The actual product may differ from the illustration because this manual is intended chiefly to explain the procedures for using the product.

# **Chapter1 LIST OF TOOLS TO BE USED**

## LIST OF TOOLS TO BE USED

The following tools are needed for installation, adjustment, and maintenance purposes.

Component	Where to use	Tool	
Cycle computers (SC-E8000)	Clamp bolt		3 mm hexagon wrench
Cycle computers (SC-E6010)	Handlebar fixing bolt		Screwdriver [#2]
	Angle adjustment screw		Screwdriver [#2]
Assist switch (SW-M9050/SW-E8000)	Unit fixing bolt		3 mm hexagon wrench
	Lever fixing bolt		2 mm hexagon wrench
Assist switch (SW-E6010)	Fixing bolt		3 mm hexagon wrench
Electric wire	Connector	TL-EW02	TL-EW02
Battery mount (BM-E8010)	Mount lower case	 	3 mm hexagon wrench / 8 mm spanner
	Key unit		3 mm hexagon wrench
	Key unit cover		2.5 mm hexagon wrench
	Mount upper case		2.5 mm hexagon wrench

Component	Where to use	Tool	
Battery mount (BM-E8020)	Mount lower case		5 mm hexagon wrench
	Mount upper case		Screwdriver [#2]
	Key cylinder		2 mm hexagon wrench
	Key unit		5 mm hexagon wrench
	Key unit cover		Screwdriver [#2]
Speed sensor (SM-DUE10)	Speed sensor fixing bolt		4 mm hexagon wrench
Speed sensor (SM-DUE11)	Speed sensor fixing bolt		Hexalobular [#10]
Magnet unit	Fixing bolt		Screwdriver [#2]
Light cable	Mounting bolt		Screwdriver [#2]
Drive unit	Drive unit fixing bolt (M8)	-	-
	Cover fixing bolt (M3)		Screwdriver [#2]
Crank arm	Cap	 	TL-FC16/TL-FC18
	Stopper plate		5 mm hexagon wrench
Chain device	Guide fixing bolt (M5)		4 mm hexagon wrench
	Back plate fixing bolt (M6)		3 mm hexagon wrench
Front chainring	Lock ring	 	TL-FC39+TL-FC36

# Chapter2 INSTALLATION

# INSTALLATION

## Names of parts

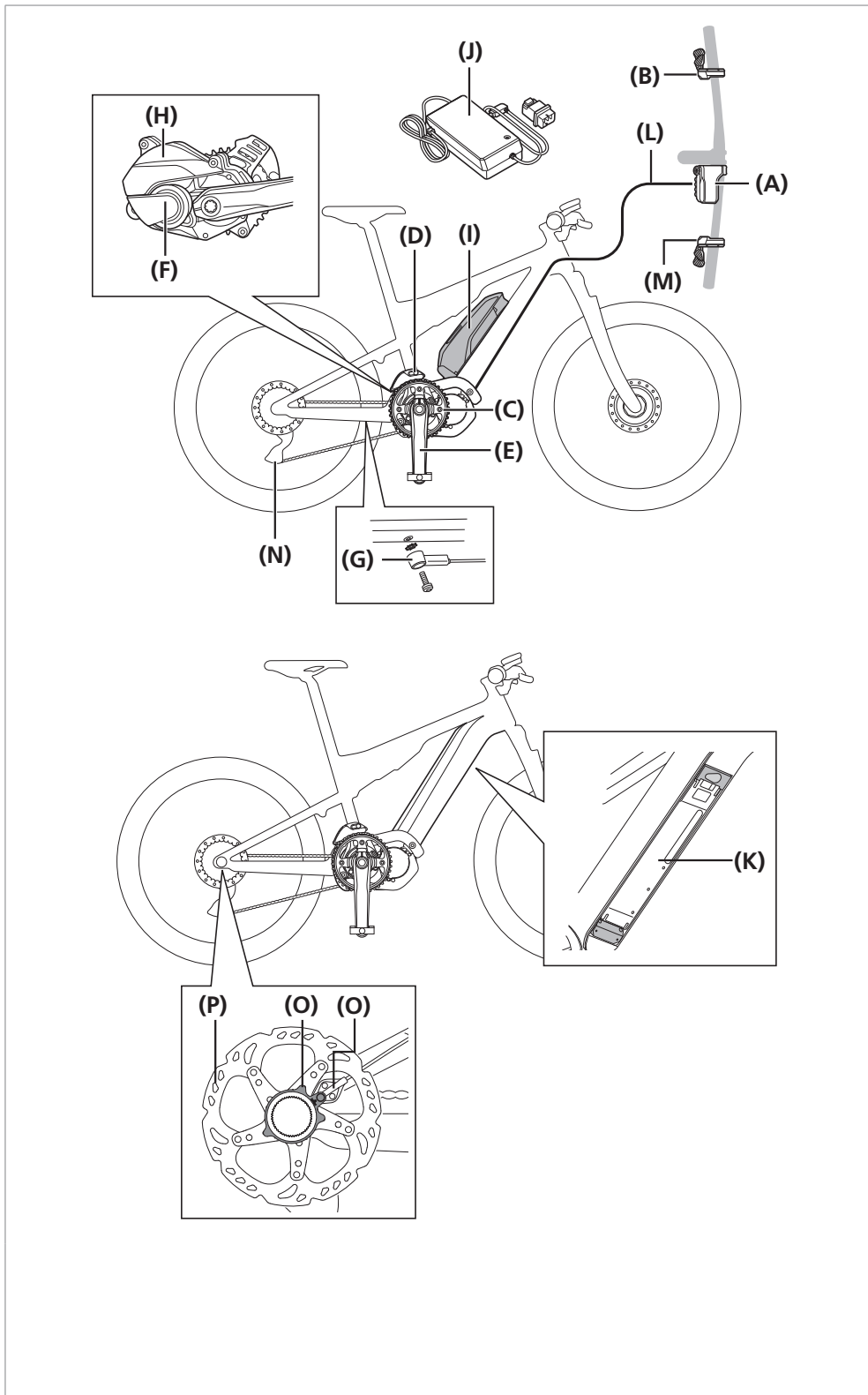

- (A)** Cycle computer:  
SC-E8000  
SC-E6010
- (B)** Assist switch:  
SW-E8000-L
- (C)** Front chainring:  
SM-CRE80/SW-E6010
- (D)** Chain device:  
SM-CDE80
- (E)** Crank arm:  
FC-E8000/FC-E8050/FC-M8050
- (F)** Drive unit:  
DU-E8000
- (G)** Speed sensor:  
SM-DUE10
- (H)** Drive unit cover:  
SM-DUE80-A  
(type that covers drive unit ports)  
SM-DUE80-B  
(type that covers drive unit ports  
and the frame installation bolts)
- (I)** Battery (external type)/  
Battery mount (external type):  
BT-E8010/BM-E8010
- (J)** Battery charger:  
EC-E6000
- (K)** Battery (built-in type)/  
Battery mount (built-in type):  
BT-E8020/BM-E8020
- (L)** E-TUBE (EW-SD50)

### When using electronic gear shifting

- (M)** Shifting switch:  
SW-M9050-R/SW-M8050-R  
SW-E6010
- (N)** Rear derailleur (DI2):  
RD-M9050/RD-M8050
- (O)** Speed sensor:  
SM-DUE11
- (P)** Disc brake rotor:  
RT-EM800/RT-EM900



### TECH TIPS

Maximum cable length (EW-SD50)  
(L) ≤ 1,600 mm

## ■ Product specifications

Operating temperature range: During discharge	-10 – 50 °C	Battery type	Lithium Ion Battery
Operating temperature range: During charging	0 – 40 °C	Nominal capacity	Refer to the user's manual for the battery "UM-70F0A". For the latest information on manuals, see the website ( <a href="http://si.shimano.com">http://si.shimano.com</a> ).
Storage temperature	-20 – 70 °C	Rated voltage	36 V DC
Storage temperature (Battery)	-20 – 60 °C	Drive unit type	Midship
Charging voltage	100 – 240 V AC	Motor type	Brush-less DC
Charging time	Refer to the user's manual for the battery "UM-70F0A". For the latest information on manuals, see the website ( <a href="http://si.shimano.com">http://si.shimano.com</a> ).	Rated drive unit power	250 W

\* The maximum speed up to which power assistance is provided is set by the manufacturer and is conditional on where the bicycle is to be used.

## ■ Installing the cycle computer

SC-E8000

**1**

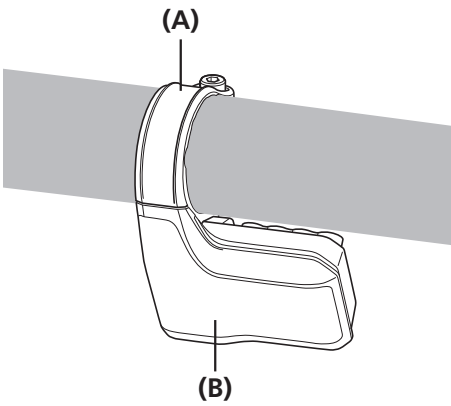

(A)

(B)

Pass the clamp band on the cycle computer over the handlebar.

- (A) Clamp band
- (B) Cycle computer

**2**

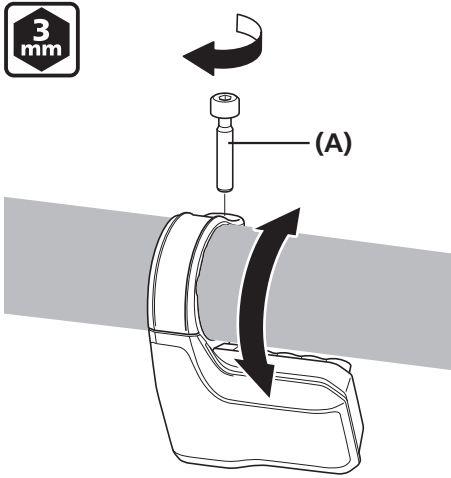

3 mm

(A)

Adjust the angle of the cycle computer so that it is easy to see, and then use a 3 mm hexagon wrench to tighten the clamp bolt.

- (A) Clamp bolt

Tightening torque	
3 mm	0.8 N·m

**NOTE**

Recommended installation angle of the information display: Between 15° to 35° to the horizontal.

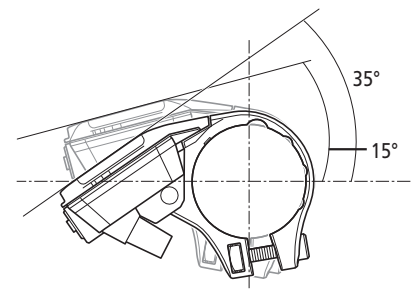

SC-E6010

**1** Open the clamp (B) and attach it to the handlebar.

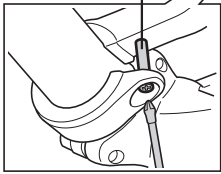
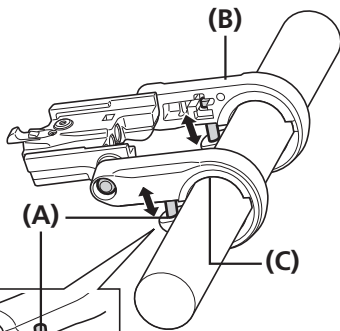

Attach the handlebar fixing bolt (A) and tighten to the specified tightening torque using a screwdriver.

- (A) Handlebar fixing bolt
- (B) Clamp
- (C) Adapter

Handlebar compatibility table

øA	øB-øA	Adapter	Fixing bolt
ø23.4-ø24	0-1.1	X	15.5 mm
ø24-ø25.5	0-1.1	X	20 mm
ø31.3-ø31.9	0-0.6	-	20 mm

\* X: OK

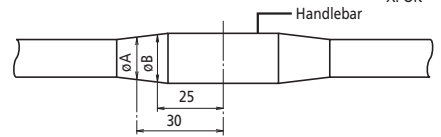

Tightening torque



1 N·m



TECH TIPS

When removing the cycle computer, reverse the procedure.

2

## ■ Installing and removing the cycle computer (SC-E6010)

1

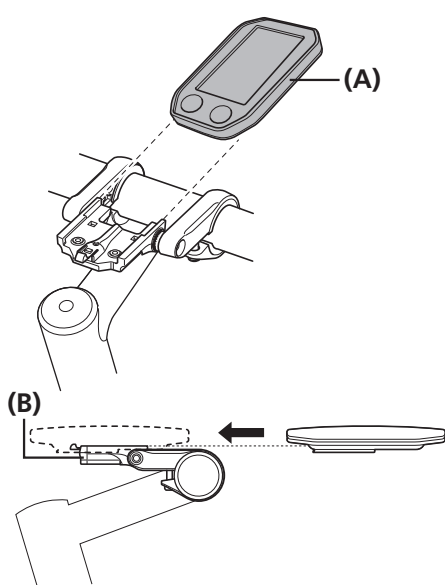

Slide the cycle computer (A) into the bracket (B) as shown in the illustration. Insert it firmly until you hear it click.

- (A) Cycle computer
- (B) Bracket

2

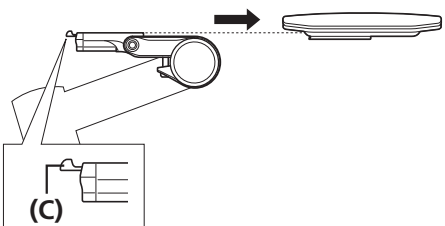

To remove the cycle computer, slide it while pushing the bracket lever (C).

- (C) Lever

**NOTE**

If the cycle computer is not in the correct place, the assist function will not operate normally.

## ■ Adjusting the angle of the cycle computer (SC-E6010)



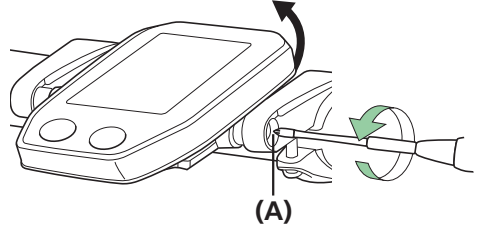

Loosen the angle adjustment screw (A) with a screwdriver. Adjust the angle of the cycle computer to make it easier to see while riding. After determining the angle, tighten the screw to the designated torque.

- (A) Angle adjustment screw

Tightening torque	
	0.5 N·m

## ■ Installing the assist switch

SC-E8000

**1**

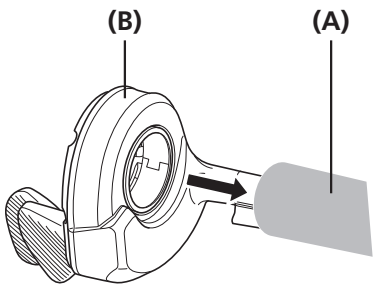

Pass the assist switch over the handlebar.

(A) Handlebar  
(B) Assist switch

**(A)** Handlebar  
**(B)** Assist switch

---

 **TECH TIPS**

Supported handlebars:  
Ø22.0 mm/Ø22.2 mm/Ø22.5 mm

**2**

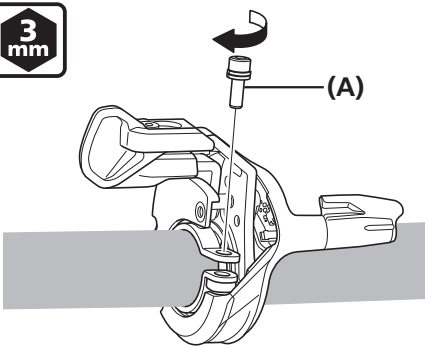

Adjust the attachment position and angle, and then use a hexagon wrench to tighten the unit fixing bolt.

(A) Unit fixing bolt

**(A)** Unit fixing bolt

---

Tightening torque	
	2 - 2.2 N·m

---

**NOTE**

Attach the lever in a position where it will not touch the brake lever when pushed all the way in.

**3**

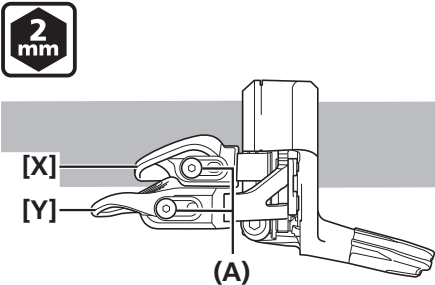

Adjust the positions of lever [X] and lever [Y].

Loosen the lever fixing bolt using an 2 mm hexagon wrench, and adjust the lever's position so that it is easy to push.

After determining the position, tighten to the designated torque.

(A) Lever fixing bolt

**(A)** Lever fixing bolt

---

Tightening torque	
	0.5 - 0.7 N·m

▶▶ Using the cable band to attach the assist switch to the handlebar

## ■ Using the cable band to attach the assist switch to the handlebar

SW-E6010

1

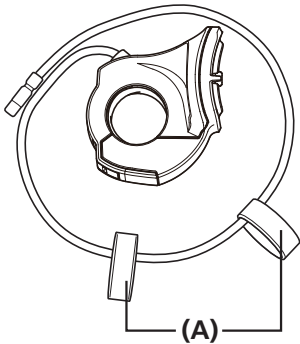

Temporarily attach the cable band (A) to the assist switch. Adjust the cable band according to the length of the handlebar.

(A) Cable band



TECH TIPS

The cable band is included in SW-E6010.

2

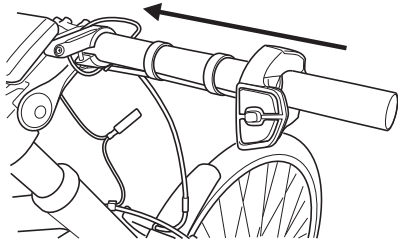

Attach the assist switch mounted with the cable band to the handlebar.

## ■ Installing the assist switch

**1**

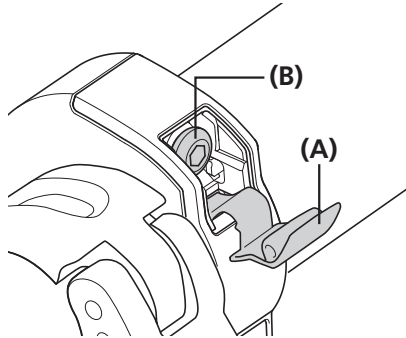

Attach the assist switch to a  $\varnothing 22.2$  handlebar with the electric wire routed under the switch and open the fixing bolt cover (A).

- (A) Fixing bolt cover
- (B) Fixing bolt

**2**

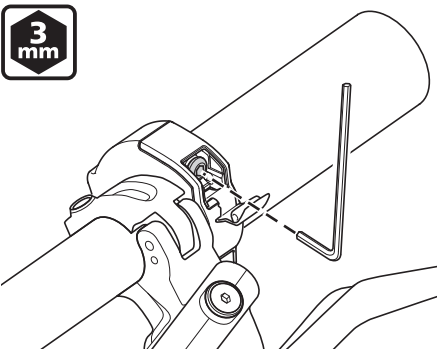

Tighten the fixing bolt (B) to the specified tightening torque using a 3 mm hexagon wrench.

Tightening torque	
	1.5 N·m

 **TECH TIPS**

When removing the cycle computer, reverse the procedure.

## ■ Connecting the electric wire

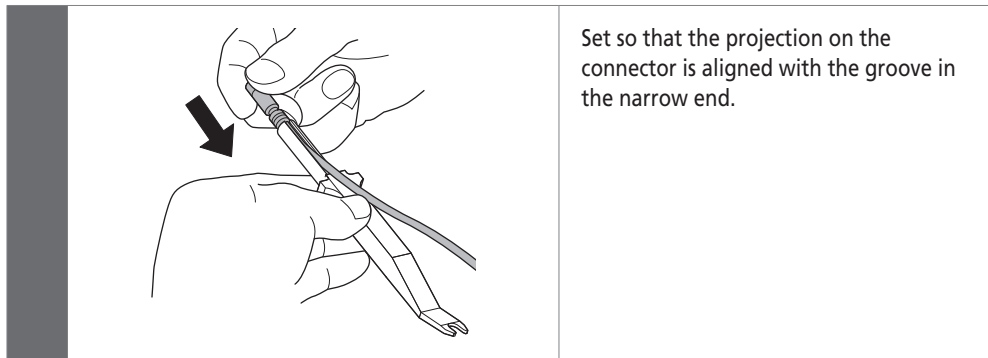

Set so that the projection on the connector is aligned with the groove in the narrow end.

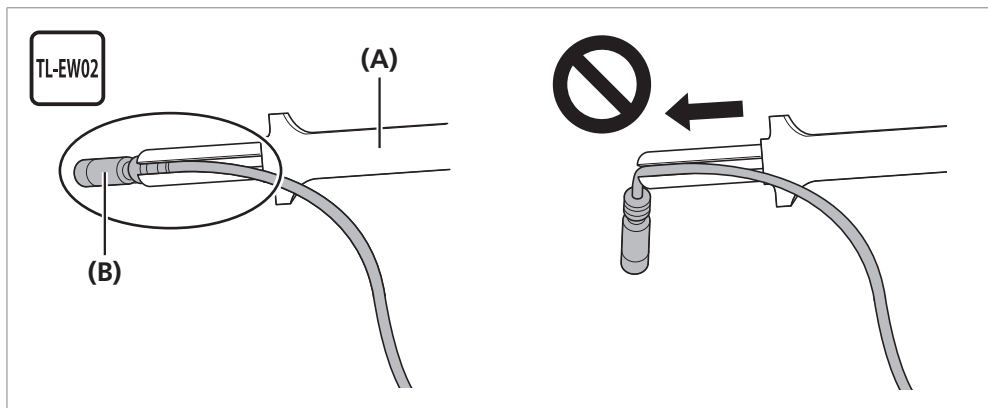

(A) TL-EW02

(B) Plug

### NOTE

Use the Shimano original tool for installation and removal of the electric wire. When installing the electric wire, do not forcibly bend the plug. It may result in a poor contact. When connecting the electric wire, push it in until it clicks in place.

## Connect the electric wire to the assist switch

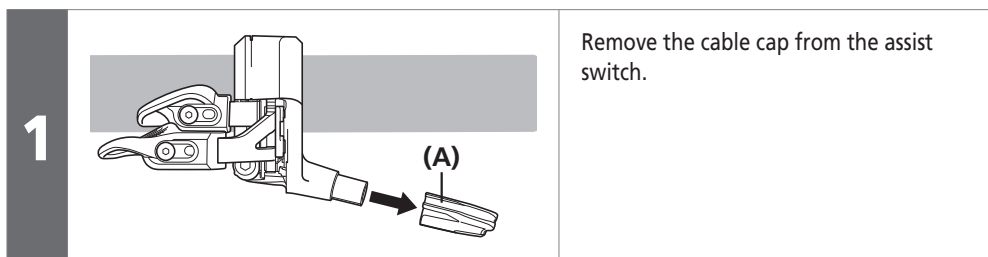

Remove the cable cap from the assist switch.

(A) Cable cap

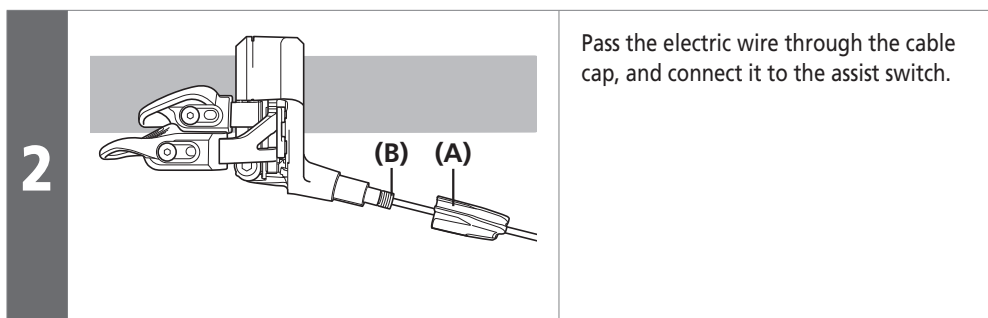

Pass the electric wire through the cable cap, and connect it to the assist switch.

(A) Cable cap

(B) Electric wire

### NOTE

Make sure the electric wire is connected through the cable cap. If the wire is not passed through the cable cap, the electric wire connector may be damaged.

3

When routing the electric wire in the direction of the stem

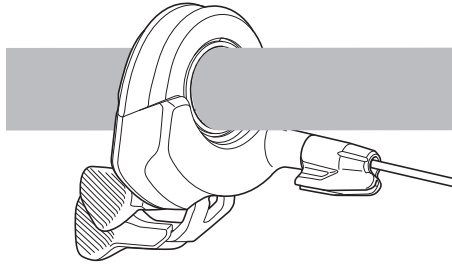

When using a cable built-in handlebar

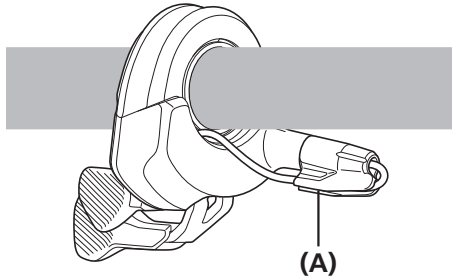

Install the cable cap.

When routing the electric wire along a cable built-in handlebar, run the wire along the guide of the cable cap then the handlebar.

(A) Guide

### Securing the electric wire (SC-E8000)

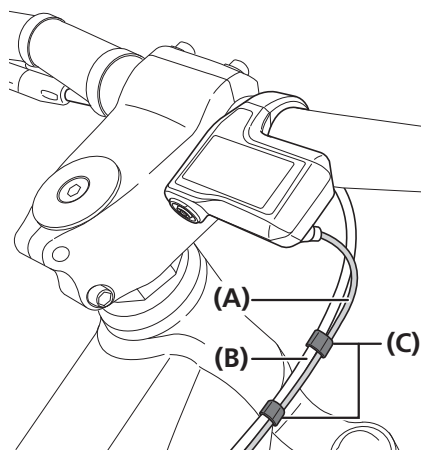

Bind the brake horse (or brake outer casing) to the electric wire connecting the cycle computer and drive unit, using the band, as shown in the illustration.

- (A) Electric wire of the cycle computer
- (B) Brake horse (or brake outer casing)
- (C) Band



TECH TIPS

The band is included in SC-E8000.

Example of routing the electric wire (SW-E6010)

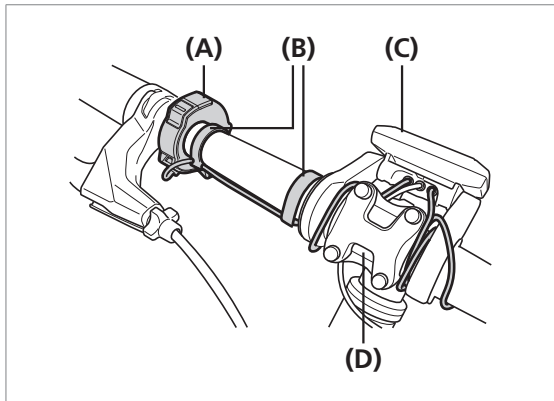

**Example 1:** Secure the electric wire of the assist switch (A) to the handlebar using the cable band (B). Wind the excess electric wire around the area between the cycle computer (C) and stem (D), then connect the wire to the cycle computer.

- (A) Assist switch
- (B) Cable band
- (C) Cycle computer
- (D) Stem

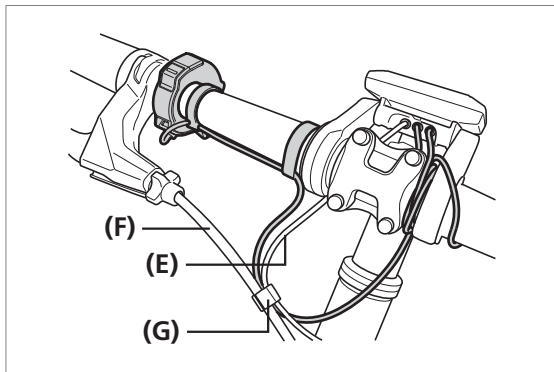

**Example 2:** Secure the electric wire of the assist switch to the handlebar using the cable band. Bind the electric wire of the assist switch and that of the cycle computer (E) to the brake outer casing (F) using the band (G) and connect the electric wire of the assist switch to the cycle computer.

- (E) Electric wire of the cycle computer
- (F) Brake outer casing
- (G) Band



The band is included in SC-E6010.

## ■ Installing the battery mount

BM-E8010

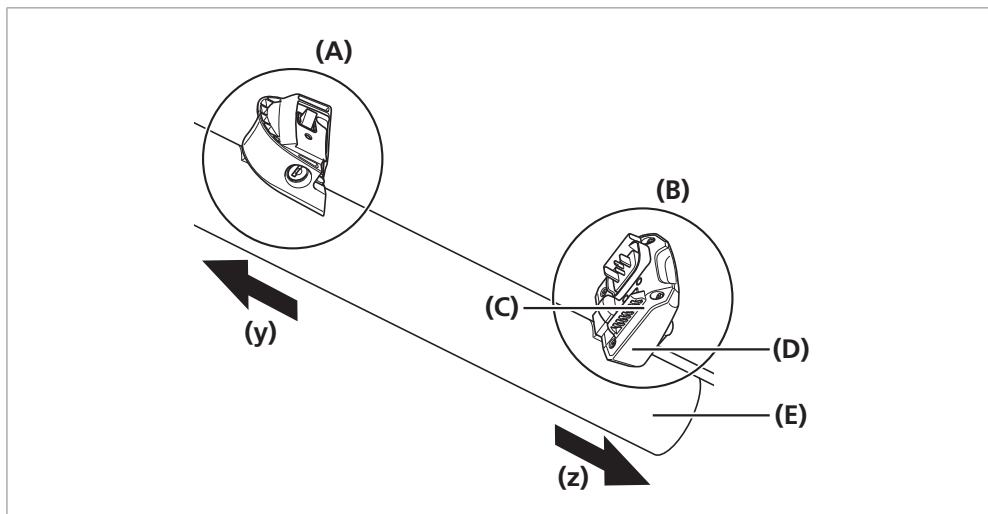

(y) Front of bicycle

(z) Rear of bicycle

(A) Key unit

(B) Battery connection unit

(C) Mount upper case

(D) Mount lower case

(E) Frame

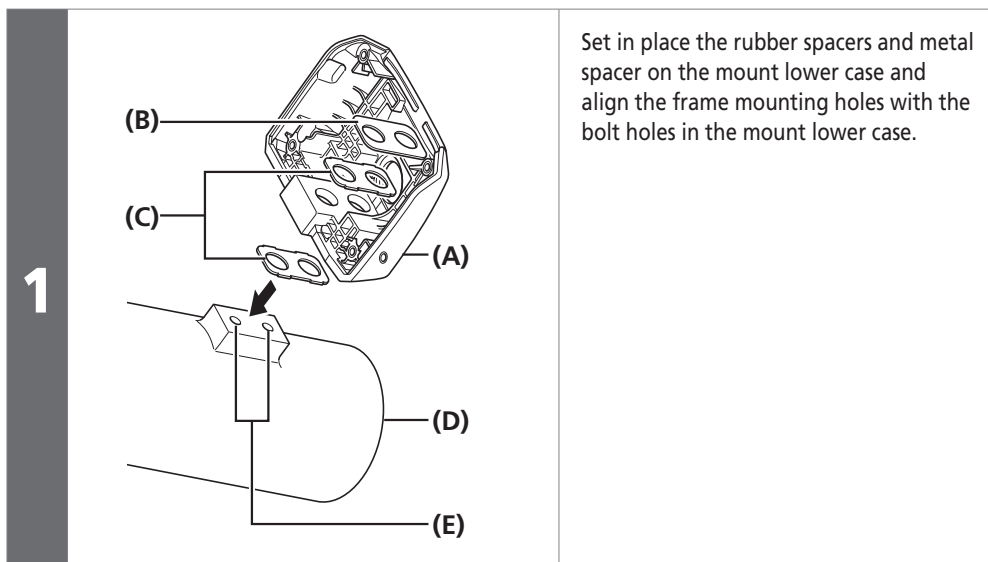

Set in place the rubber spacers and metal spacer on the mount lower case and align the frame mounting holes with the bolt holes in the mount lower case.

(A) Mount lower case

(B) Metal spacer

(C) Rubber spacer

(D) Frame

(E) Frame mounting holes

1

▶▶ Installing the battery mount

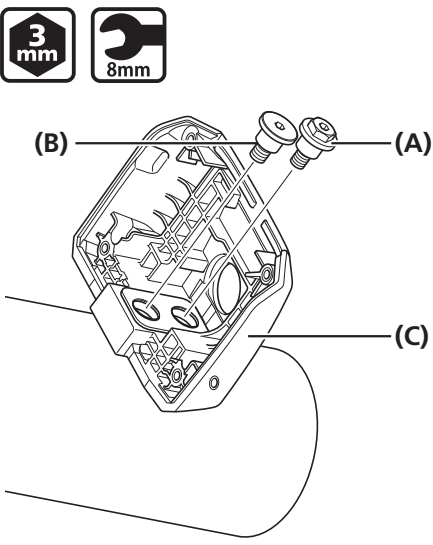

2



Secure the mount lower case by tightening the two types of mount fixing bolt (M5).

Tighten the mount fixing bolt (M5) (low head type) first.

- (A)** Mount fixing bolt (M5) (hexagon bolt type):  
Use a 3 mm hexagon wrench or 8 mm spanner on the mount fixing bolt.
- (B)** Mount fixing bolt (M5) (low head type):  
Use a 3 mm hexagon wrench on the mount fixing bolt.
- (C)** Mount lower case

Tightening torque	
 	3 N·m

3

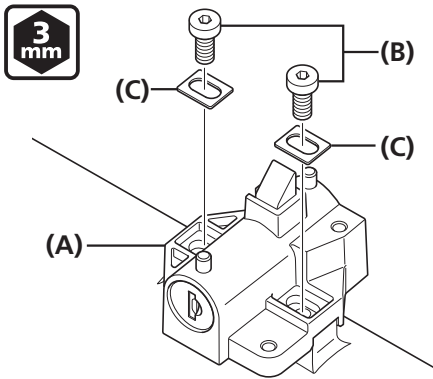

Temporarily attach the key unit with the key unit fixing bolts (M5).

- (A)** Key unit:  
Key unit is not included with Shimano products.
- (B)** Key unit fixing bolt (M5)
- (C)** Washer

4

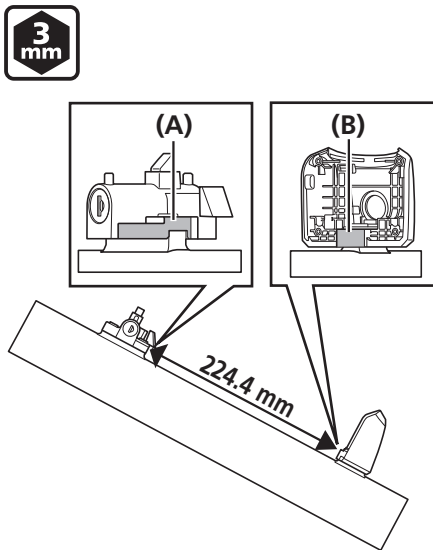

Adjust the position of the key unit so that the distance between section (A) of the key unit and section (B) of the mount lower case is 224.4 mm and then fully tighten the key unit fixing bolts.

Tightening torque	
	3 N·m

▶▶ Installing the battery mount

5

Temporarily attach the key unit cover to the key unit and adjust so that the battery can be smoothly connected/ disconnected and no noise is produced due to looseness during riding.

- (A)** Key unit cover
- (B)** Battery

6

Secure the key unit cover with the key unit cover fixing bolts (M4).

- (A)** Key unit cover
- (B)** Key unit cover fixing bolt (M4)

Tightening torque	
	0.6 N·m

7

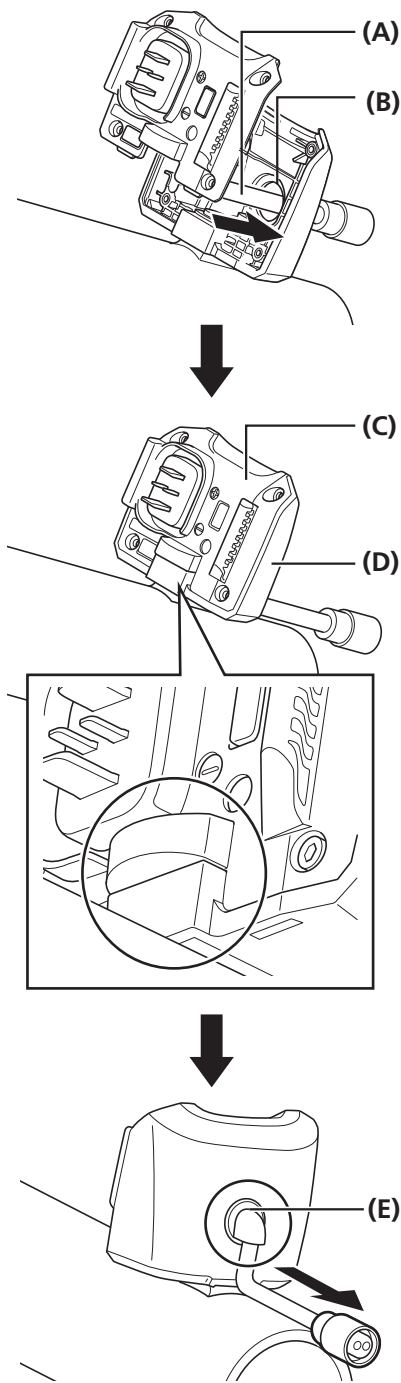

Route the power cord through the cable routing hole.

Align the protruding parts of the mount upper case and mount lower case.

Pull the power cord until the rubber bush is implanted in the cable routing hole.

- (A) Power cord
- (B) Cable routing hole
- (C) Mount upper case
- (D) Mount lower case
- (E) Rubber bush

8

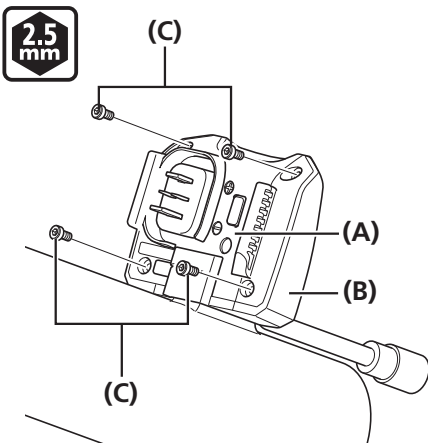

Tighten on the mount upper case using the mount upper case fixing bolts (M3).

- (A) Mount upper case
- (B) Mount lower case
- (C) Mount upper case fixing bolt (M3)

Tightening torque	
	0.6 N·m

BM-E8020

Assembly of the battery connection unit

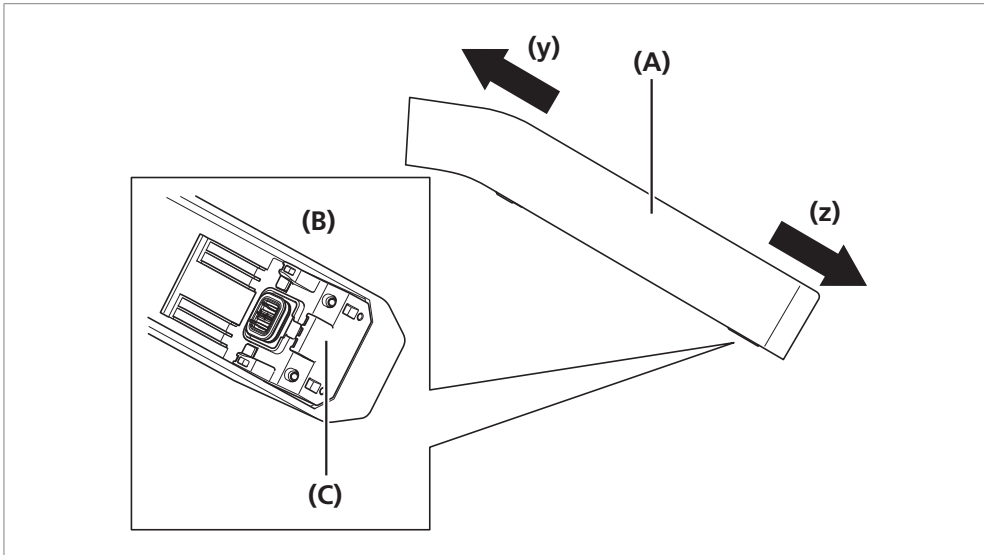

(y) Front of bicycle

(z) Rear of bicycle

(A) Frame

(B) Battery connection unit

(C) Mount upper case and mount lower case when assembled

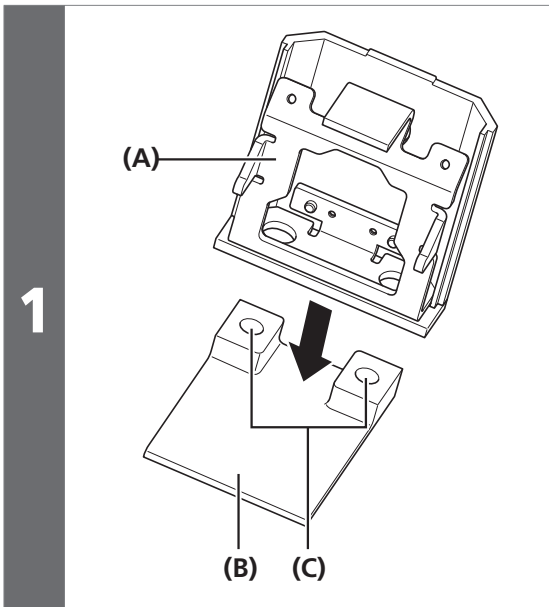

Align the frame mounting holes with the bolt holes in the mount lower case.

(A) Mount lower case

(B) Frame

(C) Frame mounting holes

2

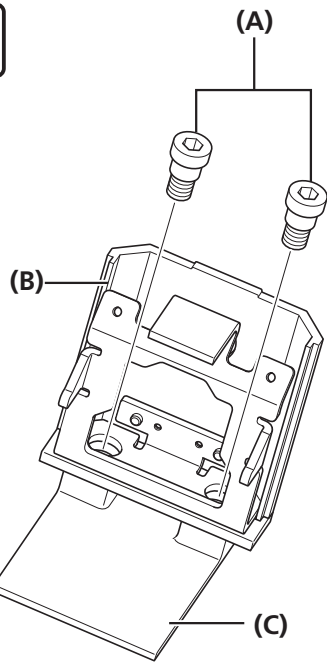

Secure the mount lower case to the frame by the tightening the mount fixing bolts (M8).

- (A) Mount fixing bolt (M8)
- (B) Mount lower case
- (C) Frame

Tightening torque



10 N·m

3

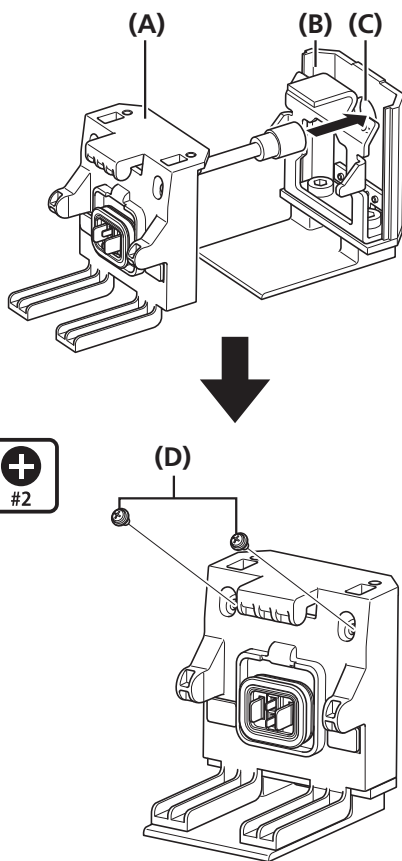

Route the power cord through the cable routing hole in the mount lower case and then tighten on the mount upper case using the mount upper case fixing bolts (M3).

- (A) Mount upper case
- (B) Mount lower case
- (C) Cable routing hole
- (D) Mount upper case fixing bolt (M3)

Tightening torque



0.6 N·m

Assembly of the key unit

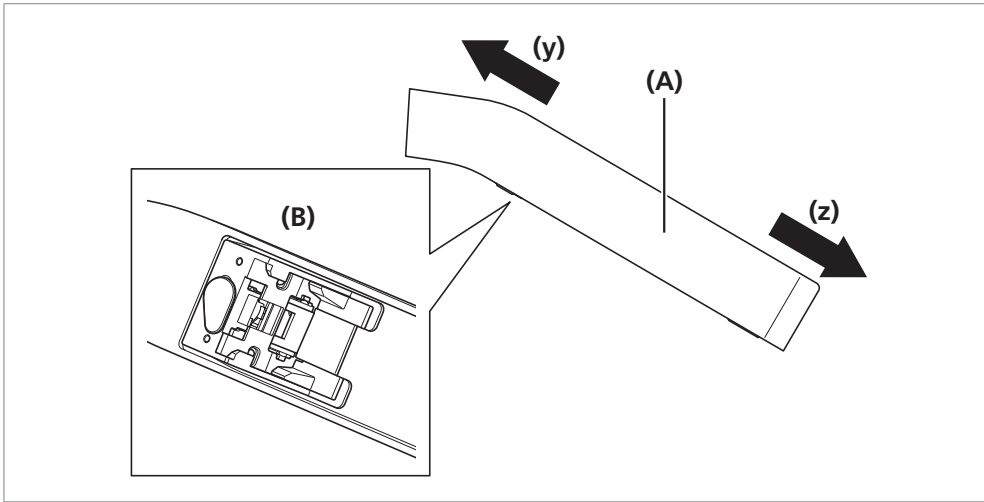

(y) Front of bicycle

(z) Rear of bicycle

(A) Frame

(B) Key unit

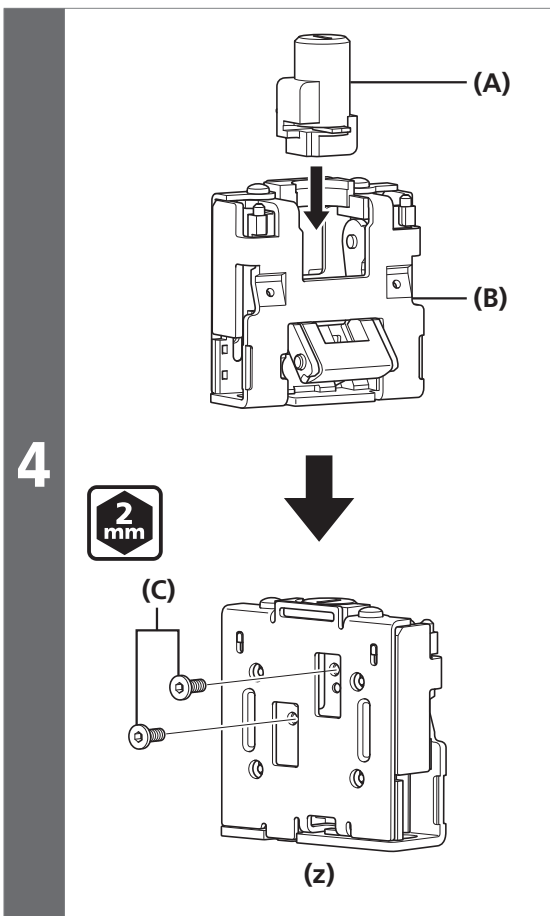

Insert the key cylinder into the key unit.

Secure the key cylinder in place by tightening the key cylinder fixing bolts (M4) from the reverse side of the key unit.

(z) Reverse side of key unit

(A) Key cylinder:

Key cylinder is not included with Shimano products.

(B) Key unit

(C) Key cylinder fixing bolt (M4)

Tightening torque	
	0.6 N·m

4

▶ Installing the battery mount

5

Align the fixing bolt holes in the key unit with the frame mounting holes.

Temporarily attach the key unit to the frame with the key unit fixing bolts (M8).

Attach the bolt fork end prevention rubbers.

- (A)** Key unit
- (B)** Key unit fixing bolt (M8)
- (C)** Bolt fork end prevention rubber
- (D)** Frame
- (E)** Frame mounting holes

6

Adjust the position of the key unit so that the distance between section (A) of the key unit and section (B) of the battery connection unit is 347.2 mm and then fully tighten the key unit fixing bolts.

Tightening torque	
	10 N·m

7

Temporarily attach the key unit cover to the key unit and adjust so that the battery can be smoothly connected/ disconnected and no noise is produced due to looseness during riding.

- (A)** Key unit cover
- (B)** Battery

8

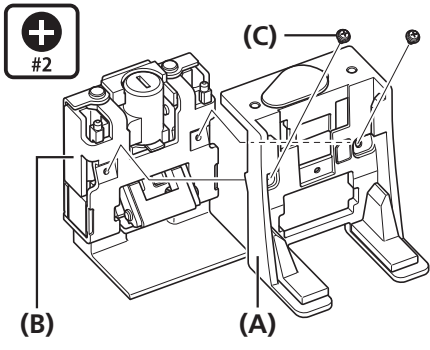

Attach the key unit cover to the key unit.

Secure in place the key unit with the key unit fixing bolts (M3).

- (A) Key unit cover
- (B) Key unit
- (C) Key unit cover fixing bolt (M3)

Tightening torque



0.6 N·m

## ■ Installing / removing the battery

### Installation of the battery

BT-E8010

1

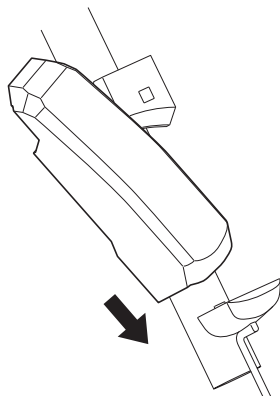

Align the indentation in the bottom of the battery with the protrusion on the mount and insert the battery.

2

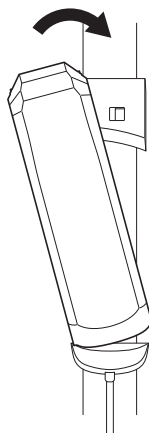

Slide the battery to the right starting from the point where it is inserted.  
Push in the battery until you hear it click.

3

Return the key to the locking position, remove it, and store it in a safe place.

#### NOTE

- To prevent the battery from falling out, check to see that the battery is locked after installation.
- Before riding, make sure that the charging port cap is closed.
- To prevent the battery from falling out, do not ride the bicycle with the key inserted.

BT-E8020

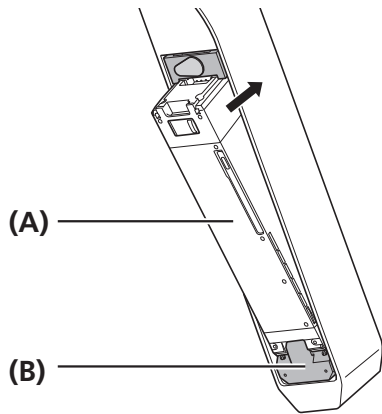

Insert the battery into the battery mount until there is a click.

- When inserted until a click is heard, the battery is locked automatically.

(A) Battery

(B) Battery mount

**NOTE**

- To prevent the battery from falling out, check to see that the battery is locked after installation.
- Before riding, make sure that the keyhole cap and charging port cap are closed.
- To prevent the battery from falling out, do not ride the bicycle with the key inserted.

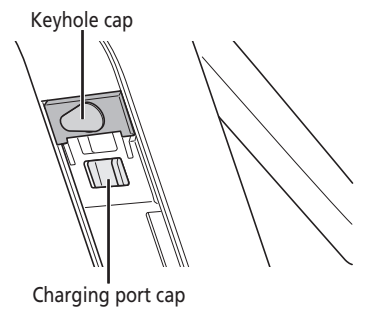

## Removing the battery

The following description may not be applicable as different types of keys are available.

BT-E8010

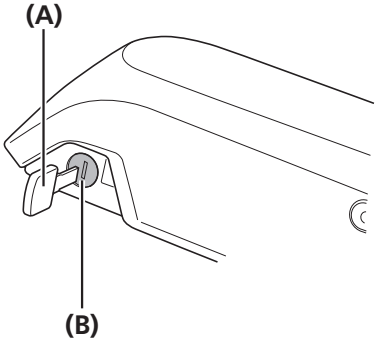
1		<p>Turn off the power, then insert the key into the key cylinder in the battery holder.</p>
---	---	---

- (A)** Key
- (B)** Key cylinder

### NOTE

Hold the battery firmly and be careful that it does not drop when removing or carrying it.

### TECH TIPS

- The position of the key does not affect the insertion of the battery. You can insert it regardless of the key position.
- You cannot remove the key when it is not in the inserting position.

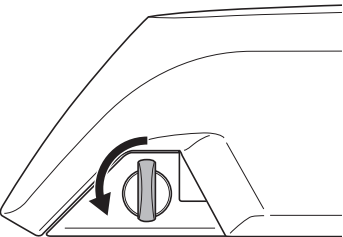
2		<p>To unlock the battery turn the key to the left until you feel some resistance.</p>
---	--	---

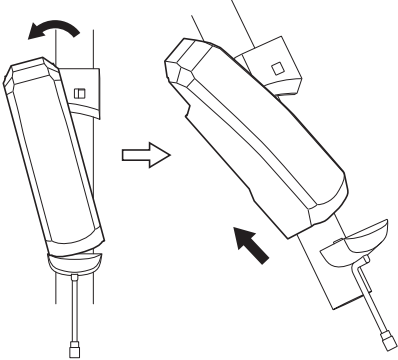
3		<p>Hold the upper part of the battery and slide it to the left to remove it.</p>
---	---	--

BT-E8020

If using a battery cover manufactured by another company, remove the battery cover before removing the battery.

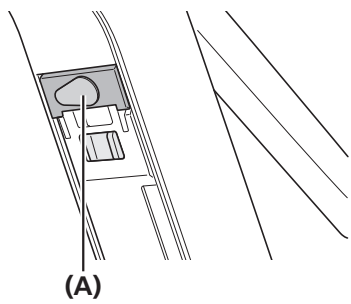
1		Remove the keyhole cap.
---	---	-------------------------

**(A)** Key hole cap

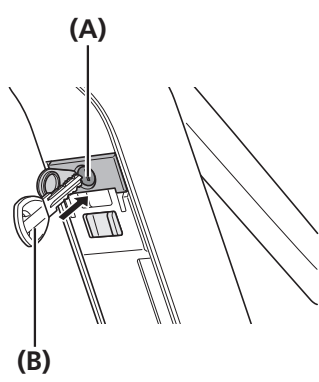
2		Insert the key into the key cylinder in the battery mount.
---	---	--

**(A)** Key cylinder  
**(B)** Key

 **TECH TIPS**

- The position of the key does not affect the insertion of the battery. You can insert it regardless of the key position.
- You cannot remove the key when it is not in the inserting position.

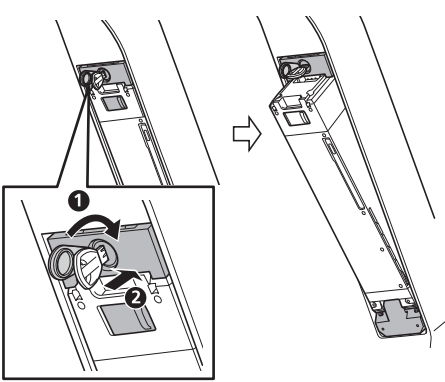
3		To unlock the battery, turn the key clockwise and push it in.
---	---	---

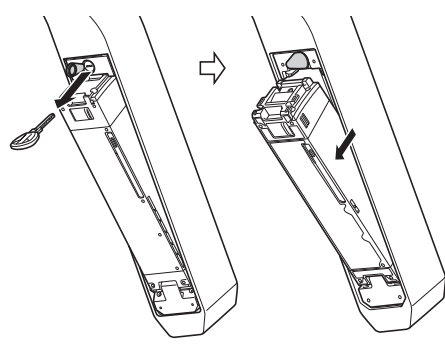
4		Remove the key from the key cylinder, close the keyhole cap, and detach the battery.
---	---	--

**NOTE**

- Support the battery with your hand when detaching to make sure that it does not fall out.
- Do not attach or detach the battery with the key left inserted into the key cylinder or the keyhole cap left open. The battery may be damaged from contact with the handle of the key or the keyhole cap.

## ■ Installing the speed sensor

SM-DUE10

**1**

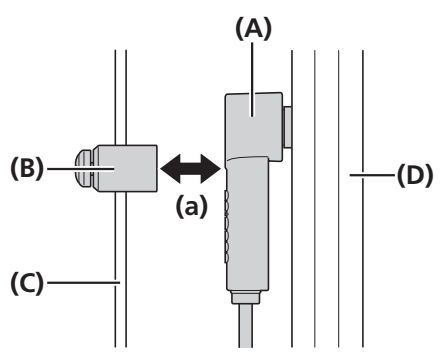

Before installing the speed sensor, check that the clearance (a) between the speed sensor and the magnet unit will be within 3 to 17 mm.

- (A) Speed sensor
- (B) Magnet unit
- (C) Spoke
- (D) Chain stay



When checking the clearance is within 17 mm, take wheel truing, frame distortion, etc. into account.

**2**

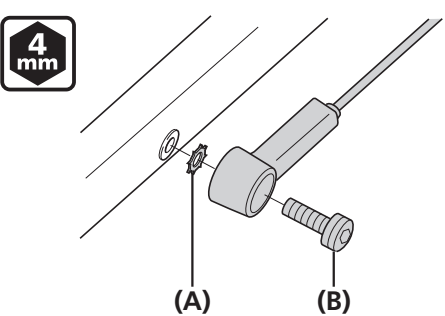

If the clearance is within the designated range, place the toothed washer between the speed sensor and the chain stay, then attach the speed sensor fixing bolt.

- (A) Toothed washer
- (B) Speed sensor fixing bolt (16 mm)

Tightening torque	
	1.5 - 2 N·m

**3**

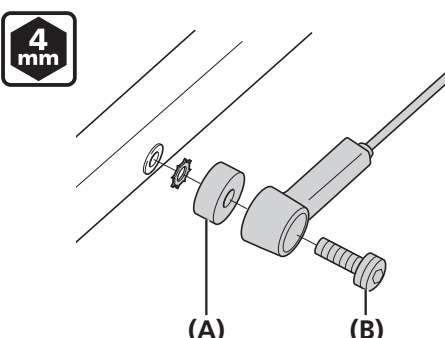

If the clearance exceeds 17 mm, use a spacer to adjust it.

Attach the speed sensor with the speed sensor fixing bolt.

- (A) Spacer
- (B) Speed sensor fixing bolt (22 mm)

Tightening torque	
	1.5 - 2 N·m

SM-DUE11

**1**

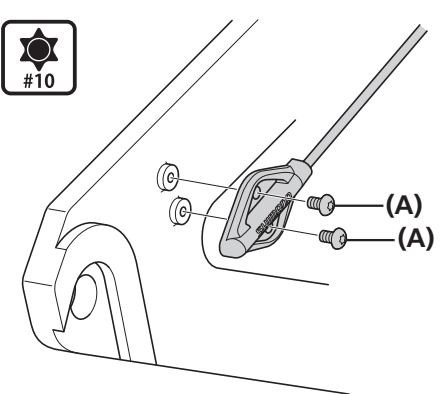

Install the speed sensor with the 2 speed sensor fixing bolts.

- (A) Speed sensor fixing bolt

Tightening torque	
	0.6 N·m

## ■ Mounting the magnet

SM-DUE10

### Magnet mounting position

Mount the magnet so that its center is aligned over the apex of the triangle symbol.

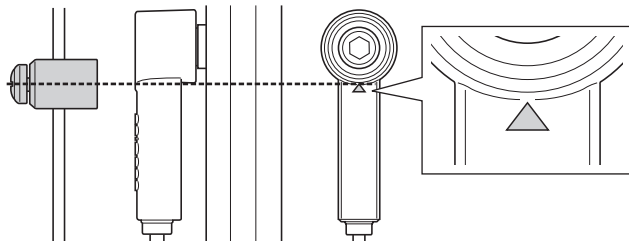

### How to mount the magnet

1

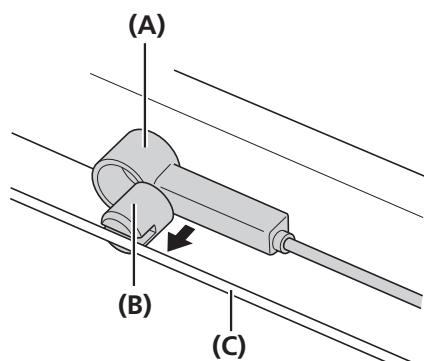

Align the speed sensor and magnet unit as shown in the illustration.

- (A) Speed sensor
- (B) Magnet unit
- (C) Spoke

2

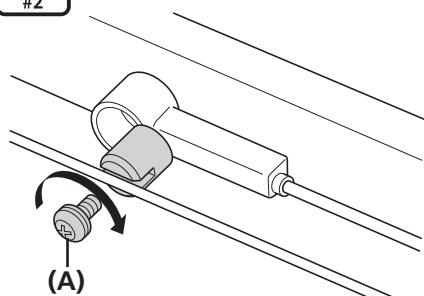

Tighten the fixing bolt with a screwdriver.

- (A) Fixing bolt

#### Tightening torque



1.5 - 2 N·m

SM-DUE11

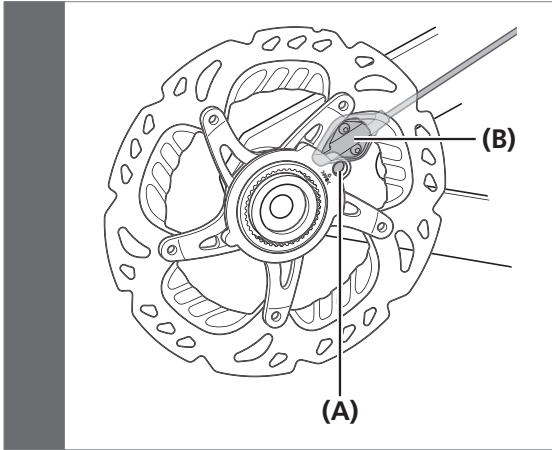

Use the special magnet model for the disc brake rotor.

(A) Magnet unit

(B) Speed sensor

**NOTE**

Refer to General Operations for installation of the disc brake rotor.

# **Chapter3 INSTALLING AND WIRING THE DRIVE UNIT**

# INSTALLING AND WIRING THE DRIVE UNIT

## ■ Installing the drive unit

Route the cables before installing the drive unit.

1

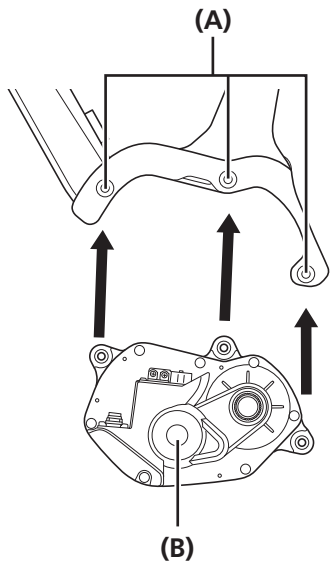

Align the drive unit with the three mounting holes on the right side and left side of the frame.

**(A)** Mounting holes  
**(B)** Drive unit

- (A)** Mounting holes
- (B)** Drive unit

**NOTE**

Be careful not to pinch the cables with the frame or drive unit case.

2

**Right side**

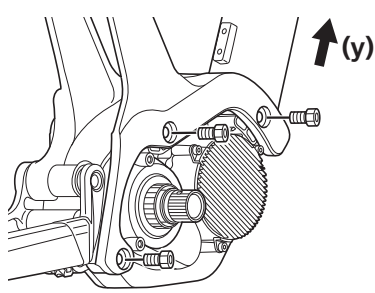

**Left side**

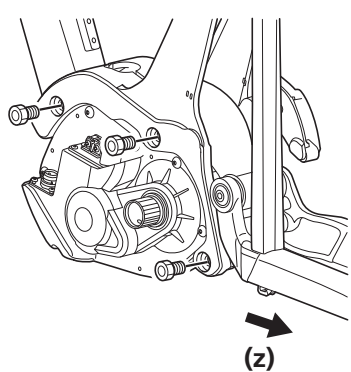

First attach the drive unit fixing bolts (M8) to the right side.

After this, attach the drive unit fixing bolts (M8) to the left side.

Tighten the drive unit fixing bolts (M8) until the drive unit makes firm contact with the inside of the right side of the frame.

**(y)** Front of bicycle  
**(z)** Rear of bicycle

**TECH TIPS**

Drive unit fixing bolts (M8) are not included with Shimano products. Use those supplied by the manufacturer. Tighten the bolts to the following tightening torque when attaching the drive unit to the frame.

Tightening torque
<b>10 - 12.5 N·m</b>

▶▶ Drive unit wiring diagram

■ Drive unit wiring diagram

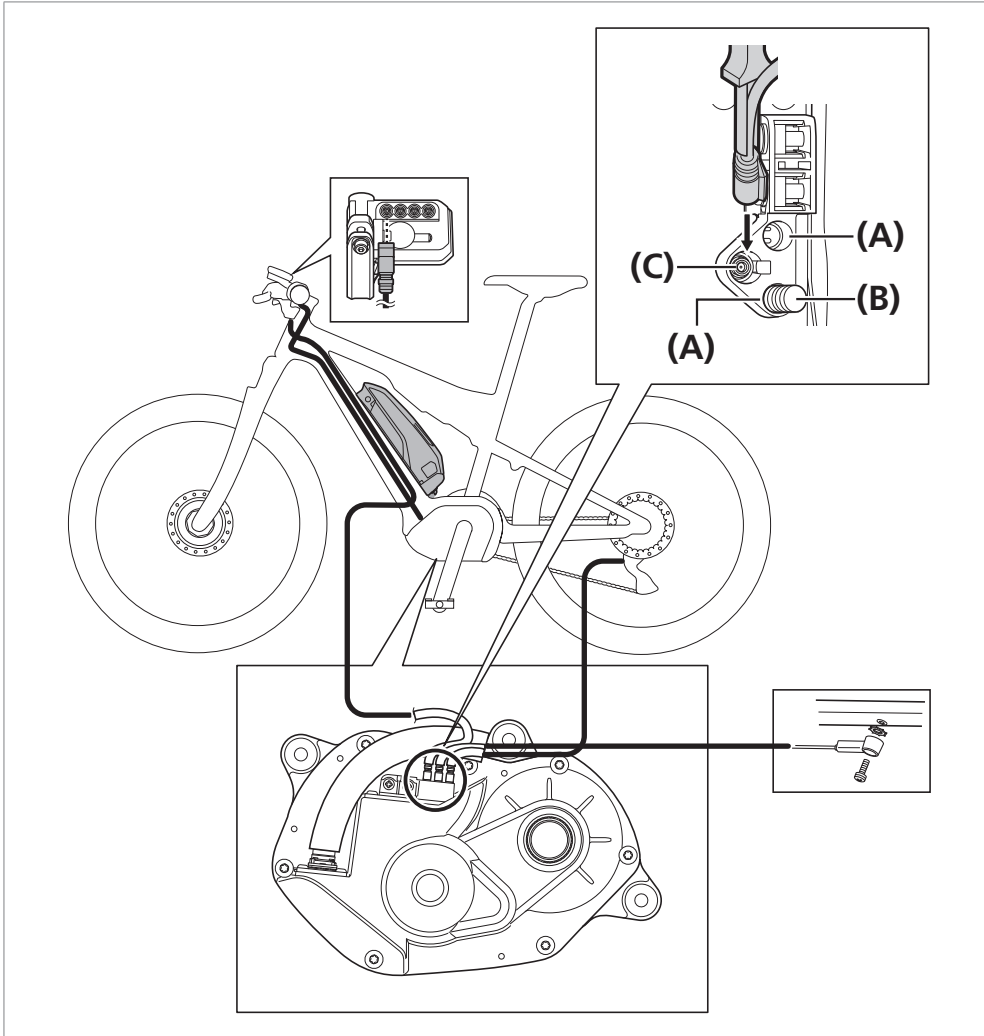

- (A) Cycle computer port/  
Rear derailleur port/E-TUBE port
- (B) Dummy plug
- (C) Speed sensor port

**NOTE**

Be sure to attach dummy plugs to any unused ports.

**TECH TIPS**

The cycle computer/rear derailleur ports can be used to connect the cycle computer or rear derailleur.

▶ Connecting the power cord

■ Connecting the power cord

Connecting to the drive unit

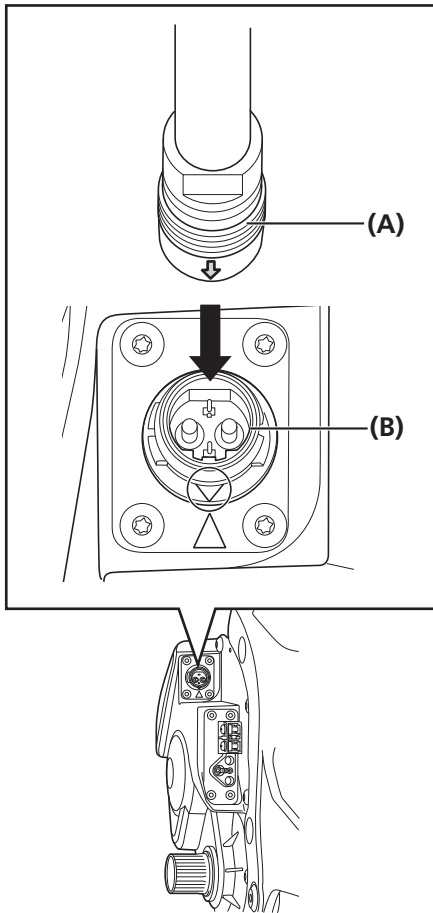

Align the arrow on the power cord with the triangle symbol on the drive unit port and insert the power cord.

Insert it until it locks into place.

- (A) Power cord
- (B) Drive unit port

Disconnecting from the drive unit

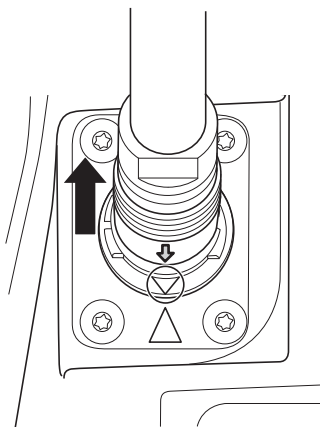

To remove the power cord, hold it by the grooved part of its end and pull it towards yourself.

▶▶ Connecting switches and the drive unit to the cycle computer (SC-E8000)

■ Connecting switches and the drive unit to the cycle computer (SC-E8000)

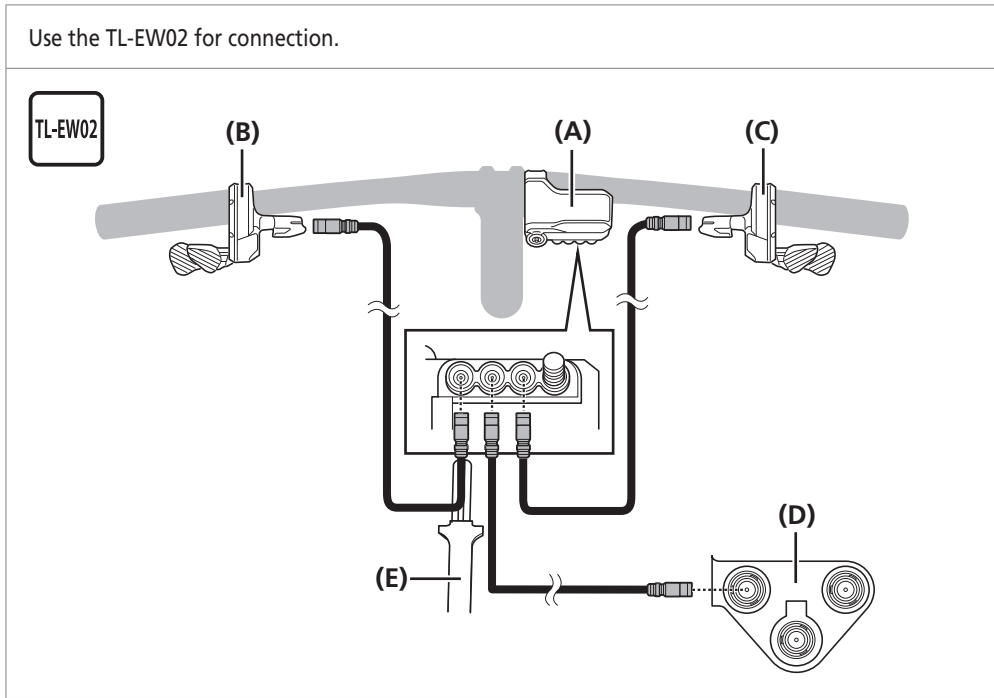

- (A) Cycle computer
- (B) Assist switch
- (C) Shift switch
- (D) Drive unit
- (E) TL-EW02

**NOTE**

Be sure to attach dummy plugs to any unused ports.

**TECH TIPS**

The electric wire connector can be connected to any port of the cycle computer, but we recommend you connect the assist switch to the switch-side port.

■ Connecting the assist switch and drive unit to the cycle computer (SC-E6010)

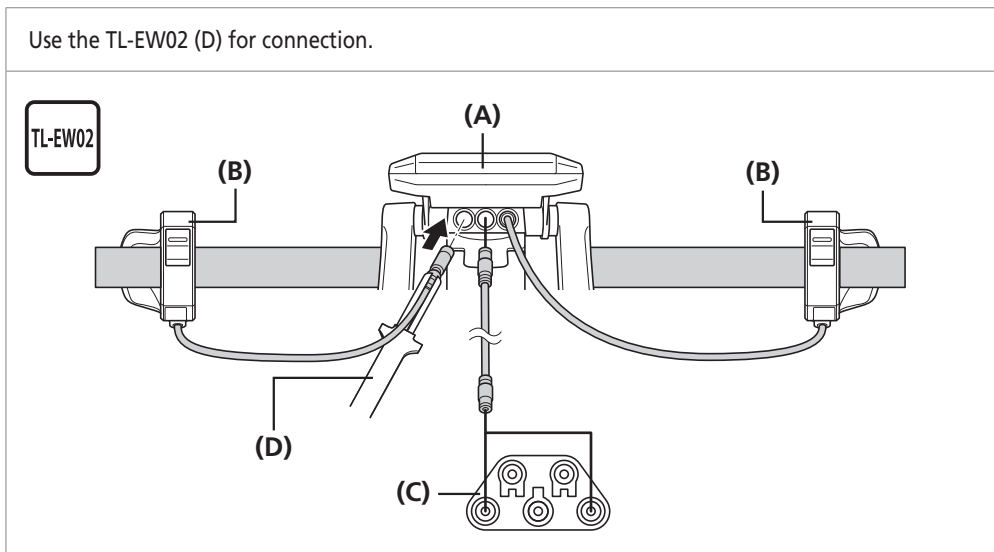

- (A) Cycle computer
- (B) Assist/Shift switch
- (C) Drive Unit
- (D) TL-EW02

**TECH TIPS**

The electric wire connector can be connected to any port of the cycle computer, but we recommend you connect the assist switch to the switch-side port.

▶▶ Connecting the speed sensor to the drive unit

■ Connecting the speed sensor to the drive unit

Connect the speed sensor unit electric wire to the drive unit speed sensor port using the TL-EW02.

TL-EW02

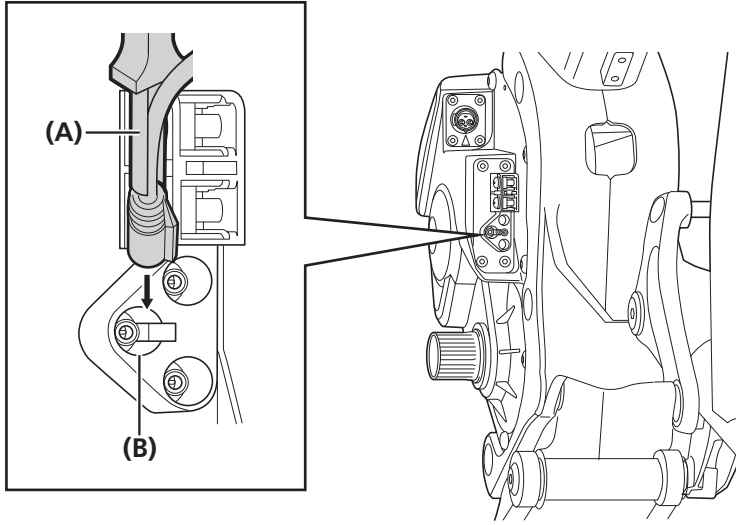

(A) TL-EW02

(B) Speed sensor port

▶▶ Connecting the light cable to the drive unit

■ Connecting the light cable to the drive unit

1

Remove the crank and drive unit cover and loosen the mounting bolts of the light connection terminals.

- (A) Light connection terminals
- (B) Mounting bolt

**TECH TIPS**

For information on compatible lights, contact a manufacturer of completed bicycles.

2

Attach the front light cable and tail light cable to the terminals and secure them with the mounting bolts.

- (A) Front light cable
- (B) Taillight cable

Tightening torque	
	0.6 N·m

3

Attach the drive unit cover.

Tighten the cover fixing bolts (M3) in the three locations.

- (A) Cover fixing bolt (M3)

Tightening torque	
	0.6 N·m

▶▶ Installing the crank and front chainring

## ■ Installing the crank and front chainring

Perform the procedure below for all models, regardless of whether gear shifting is electrical or mechanical.

1

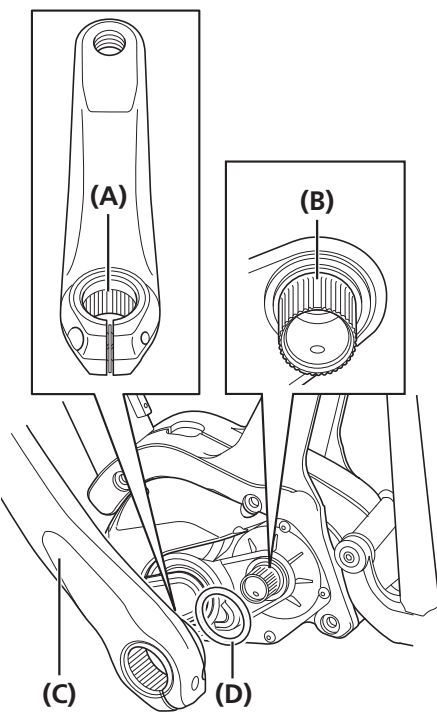

Align the wide part of the left crank arm with the wide part of the front chainring through axle and then attach.

- (A)** Wide groove area (left crank arm)
- (B)** Wide part (front chainring through axle)
- (C)** Left crank arm
- (D)** Axle spacer

**NOTE**

Left or right is indicated on each crank arm. Check the L and R markings when installing.

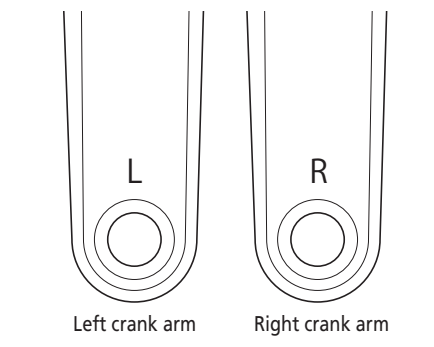

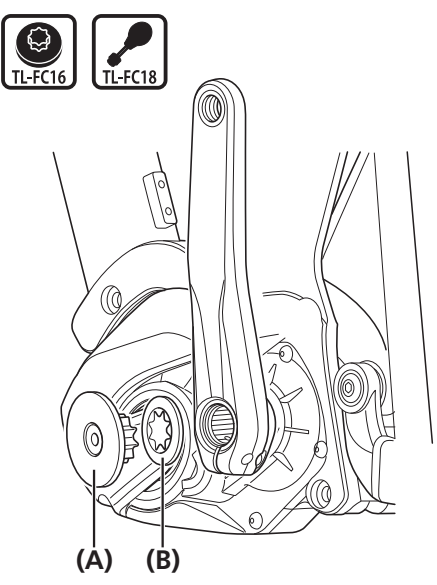

2



Use the Shimano original tool to tighten the cap.

- (A)** TL-FC16/TL-FC18
- (B)** Cap

Tightening torque	
 TL-FC16	0.7 - 1.5 N·m
 TL-FC18	

▶▶ Installing the crank and front chainring

3

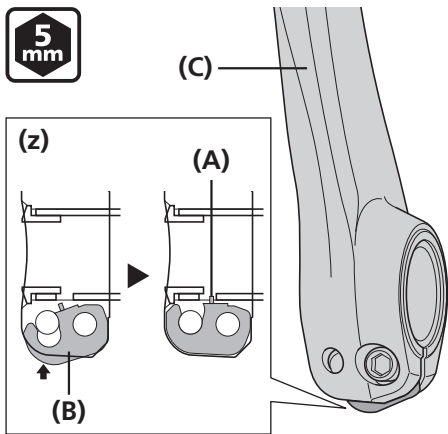

Push in the stopper plate and check that the plate pin is securely in place, and then tighten the bolt of the left crank arm.

Tighten both bolts equally to the specified tightening torque (12 - 14 N·m).

(z) The illustration is of the left crank arm (cross-section)

- (A) Plate pin
- (B) Stopper plate
- (C) Left crank arm

Tightening torque

5 mm	12 - 14 N·m
------	-------------

NOTE

- The two bolts should be tightened at the same time rather than each bolt being fully tightened separately.
- Set the stopper plate in the correct direction as shown in illustration.

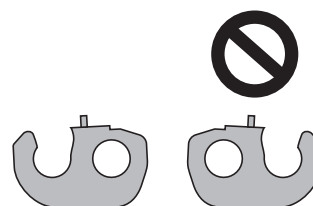

4

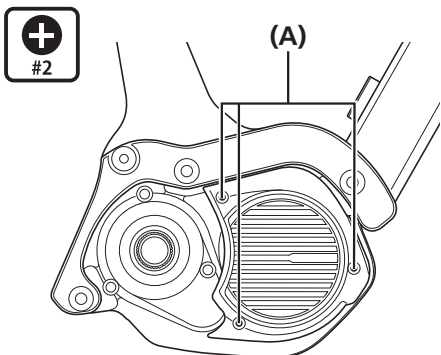

Attach the drive unit cover.

Tighten the cover fixing bolts (M3) in the three locations.

- (A) Cover fixing bolt (M3)

Tightening torque

+ #2	0.6 N·m
------	---------

5

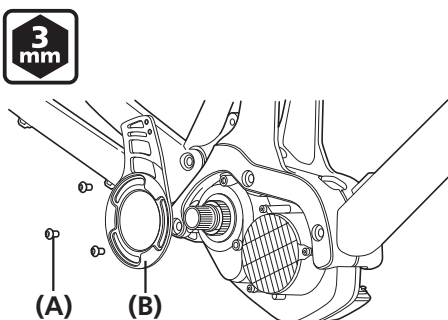

If using a chain device, temporarily tighten the back plate to the mounting member of the front chainring.

- (A) Back plate fixing bolt (M6)
- (B) Back plate

▶▶ Installing the crank and front chainring

6

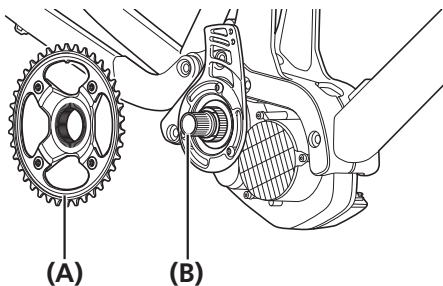

Align the cutout in the front chainring with the wide area of the front chainring mounting member when attaching the front chainring.

- (A) Front chainring (SM-CRE80-B)
- (B) Chainring mounting member

**NOTE**

- Use the front chainring and chain device combinations specified in the table.

Front chainring	Chain device
SM-CRE80 (34T/38T CL: 50 mm)	Frame mount type
SM-CRE80 (44T CL: 50 mm Double chain guard)	-
SM-CRE80-B (34T/38T CL: 53 mm)	Drive unit mount type

- Note the difference between the front and back of the chainring. The front has a gear size (tooth number) marking.

Front

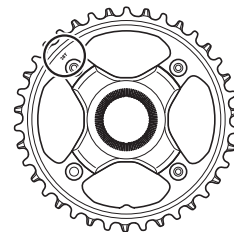

Back

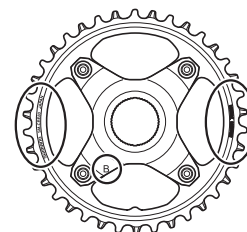

7

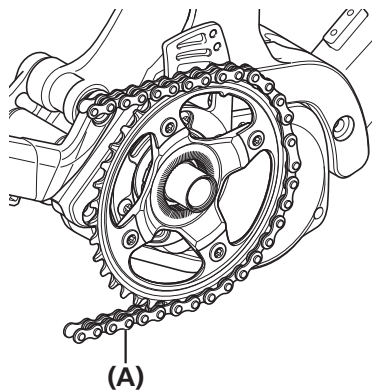

Mount the chain on the chainring.

- (A) Chain

**NOTE**

When mounting the chain, make sure to match chainring tooth thickness (thick/thin) and chain inner width (wide/narrow).

▶ Installing the crank and front chainring

8

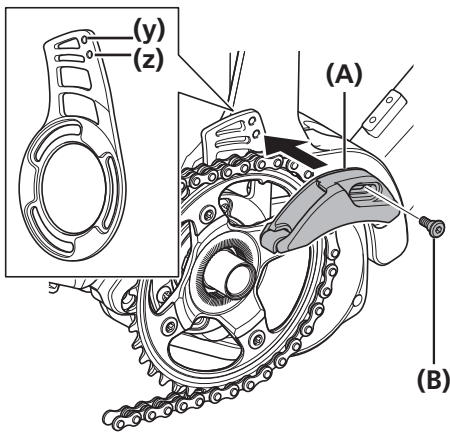

Determine the position of the guide according to the number of teeth on the crank.

Install the guide by temporarily tightening the guide fixing bolt (M5)

- (y) 38T
- (z) 34T

- (A) Guide
- (B) Guide fixing bolt (M5)

9

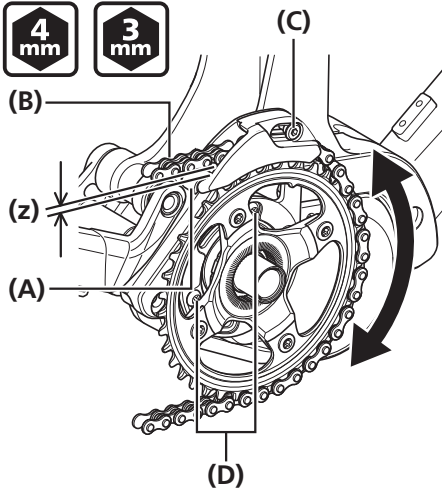

If using a chain device, after attaching the chain, rotate the back plate so that the clearance between the chain and the rubber band is 0-1 mm.

Adjustment should be performed under the following conditions.

- Chain is engaging the smallest sprocket
- Rear suspension is fully extended

After adjustment, fully tighten the back plate and guide.

- (z) 0 - 1 mm

- (A) Rubber band
- (B) Chain
- (C) Guide fixing bolt (M5)  
(4 mm hexagon wrench)
- (D) Back plate fixing bolt (M6)  
(3 mm hexagon wrench)

Tightening torque	
	4 N·m
	5 - 7 N·m

**NOTE**

If the chain and chain device interfere with each other when SM-CDE80 is used on a bicycle with Rear suspension at sag position, please adjust angle the chain device not to touch chain in the position of Low gear.

▶▶ Installing the crank and front chainring

10

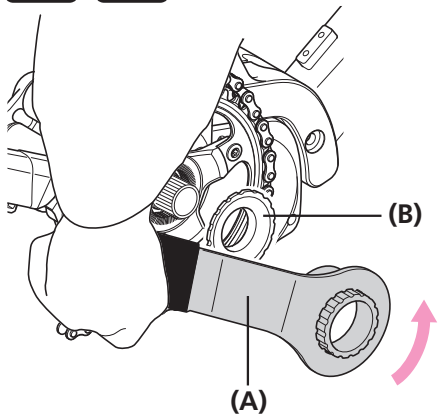

Tighten the lock ring by hand and attach the Shimano original tool.

While holding the left crank, tighten the lock ring in the direction shown in the illustration.

(A) TL-FC39/TL-FC36

(B) Lock ring

Tightening torque



35 - 45 N·m

NOTE

- If using a torque wrench, use TL-FC39 in combination with TL-FC33.

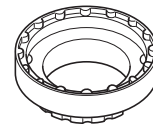

TL-FC39

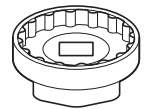

TL-FC33

- An impact wrench cannot be used.



TECH TIPS

- The lock ring has a left hand thread.
- Combine the Shimano original tools as in the illustration. Set TL-FC39 to TL-FC36 using the 2 installation holes on TL-FC39.

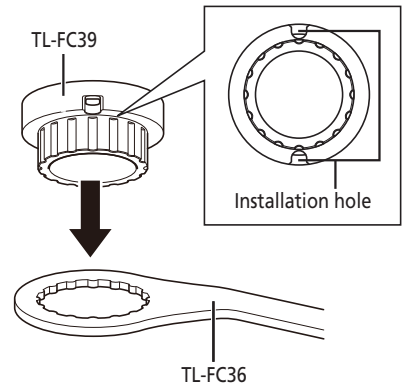

▶▶ Installing the crank and front chainring

11

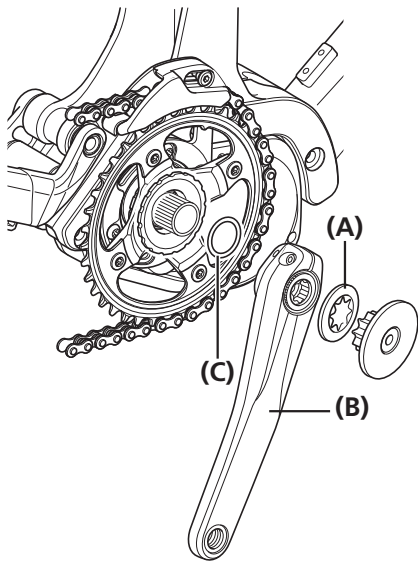

Install the right crank arm.

Use the Shimano original tool to tighten the cap.

- (A) Cap
- (B) Right crank arm
- (C) Axle spacer

Tightening torque



0.7 - 1.5 N·m

12

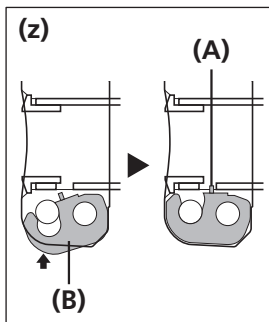

Push in the stopper plate and check that the plate pin is securely in place, and then tighten the bolt of the right crank arm.

Tighten both bolts equally to the specified tightening torque (12 - 14 N·m).

- (z) The illustration is of the right crank arm (cross-section)

- (A) Plate pin
- (B) Stopper plate
- (C) Right crank arm

Tightening torque



12 - 14 N·m

NOTE

- The two bolts should be tightened at the same time rather than each bolt being fully tightened separately.
- Set the stopper plate in the correct direction as shown in illustration.

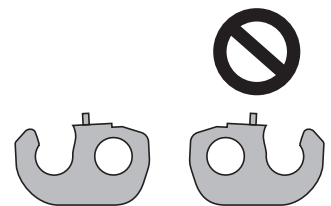

# Chapter4 CHARGING THE BATTERY

## CHARGING THE BATTERY

The battery cannot be used immediately after purchase as it will be in deep sleep mode. Charging the battery with the dedicated battery charger will release the battery from deep sleep mode, allowing the battery to be used.

The battery can be used when the LED on it turns on.

The battery can also be released from deep sleep mode by connecting to E-TUBE PROJECT when the bicycle is fitted with all components.

### ■ Proper use of the battery

**Charging can be carried out at any time regardless of the amount of charge remaining, but you should fully charge the battery in the following cases. Be sure to use the dedicated charger to charge the battery.**

- The battery is uncharged at the time of shipment. Before riding, be sure to charge the battery until it is fully charged.

**If the battery has become completely discharged, charge it as soon as possible. If you leave the battery uncharged, the battery may deteriorate.**

- If the bicycle will not be ridden for a long period of time, store it away with approximately 70% battery capacity remaining. In addition, take care not to let the battery become completely empty by charging it every 6 months.
- Do not connect to E-TUBE PROJECT while the battery is being charged.

**The use of a genuine Shimano battery is recommended. If using a battery from another manufacturer, make sure to carefully read the instruction manual for the battery before use.**

- Connect to E-TUBE PROJECT and click [Connection check] to confirm whether the battery in use is a genuine Shimano battery or another brand.

## ■ Charging the battery

### When charging the battery alone

Battery charger: EC-E6000

Battery: BT-E8010/BT-E8020

**1** Connect the battery charger's power plug to the outlet.

BT-E8010

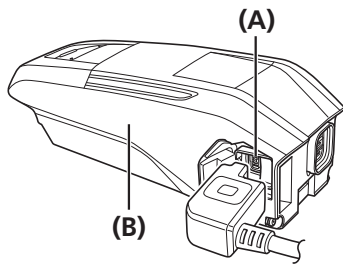

Insert the charging plug into the battery's charging port.

(A) Charging port

(B) Battery

**2**

BT-E8020

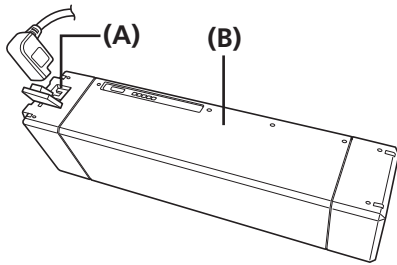

#### NOTE

Charge the battery on a flat surface indoors.

When charging the battery while it is mounted on the bicycle

Battery charger: EC-E6000  
Battery: BT-E8010/BT-E8020

**1** Connect the charger's power plug to the outlet.

BT-E8010

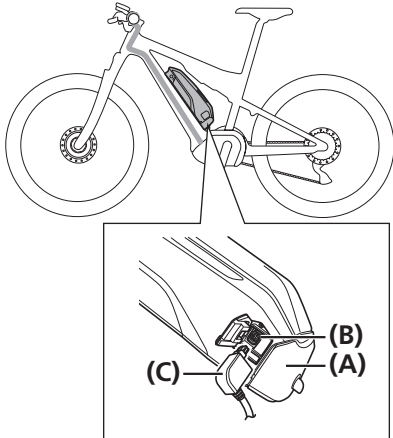

Insert the charging plug into the battery mount charging port.

- (A) Battery mount
- (B) Charging port
- (C) Charging plug

 TECH TIPS

- Place the battery charger on a steady surface such as the floor before charging.
- Stabilize the bicycle to ensure that it does not collapse during charging.

**2**

BT-E8020

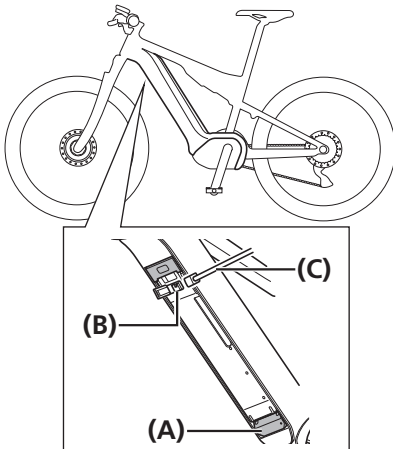

## About the charger LED lamp

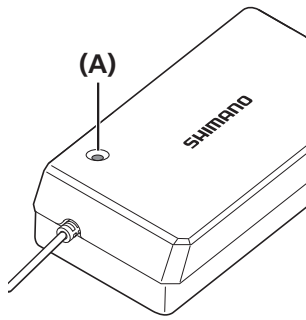

After charging has started, the LED lamp on the charger lights up.

You can check the current charging status on the battery level lamp located on the battery.

 <b>Lit up</b>	Charging (Within 1 hour after the completion of charging)
 <b>Blinking</b>	Charging error
 <b>Turned off</b>	Battery disconnected (1 hour or more after the completion of charging)

### (A) Charger LED lamp

### ⚠ DANGER

Use the battery and charger combination specified by the company for charging and follow the charging conditions specified by the company. Not doing so may cause overheating, bursting, or ignition of the battery.

### NOTE

If the bicycle is stored for an extended period of time immediately after purchase, you will need to charge the battery before using the bicycle. Once the battery is charged, it starts to deteriorate slightly.

## About the battery LED lamps

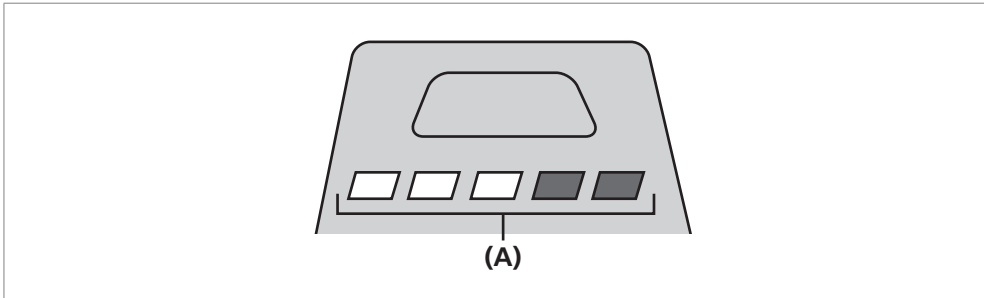

### (A) Battery LED lamp







## Charging-in-progress indication

Battery level indication *1	Battery level
	0% - 20%
	21% - 40%
	41% - 60%
	61% - 80%
	81% - 99%
	100%

\* 1 : No light : Lit up : Blinking

## Battery level indication

The current battery level can be checked by pressing the battery's power button.

Battery level indication *1	Battery level
	100% - 81%
	80% - 61%
	60% - 41%
	40% - 21%
	20% - 1%
	0% (When battery is not installed on bicycle)
	0%, Power off / Shutdown (When battery is installed on bicycle)

\* 1  : No light  : Lit up  : Blinking





### NOTE

When remaining battery capacity is low, system functions begin to shut off in the following order.

1. Power assistance (Assist mode automatically switches to [ECO] and then assistance shuts off. The switch to [ECO] occurs earlier if a battery-powered light is connected.)
2. Gear shifting
3. Light

## Error indication

System errors and similar warnings are indicated by the battery LED lamps through various lighting patterns.

Error indication type	Indication condition	Lighting pattern *1	Recovery
System error	Communication error with the bicycle system		Make sure that the cable is not loose or improperly connected. If the situation does not improve, contact an agency.
Temperature protection	If the temperature exceeds the guaranteed operating range, the battery output is turned off.		Leave the battery in a cool place away from direct sunlight until the internal temperature of the battery decreases sufficiently. If the situation does not improve, contact an agency.
Security authentication error	This is displayed if a genuine drive unit is not connected. This is displayed if any of the cables are disconnected.		Connect a genuine battery and drive unit. Check the condition of the cables. If the situation does not improve, contact an agency.
Charging error	This is displayed if an error occurs during charging.		Remove the connector between the battery and charger, and press the power switch with only the battery connected. If an error appears with only the battery connected, contact an agency.
Battery malfunction	Electrical failure inside the battery		Connect the charger to the battery and then remove the charger. Press the power switch with only the battery connected. If an error appears with only the battery connected, contact an agency.

\* 1  : No light  : Lit up  : Blinking

## ■ Turning the power ON / OFF

### Turning the power ON and OFF via the cycle computer

< SC-E6010 >

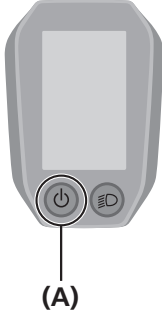

Hold down the power button (A) on the cycle computer for 2 seconds.

(A) Power button

#### NOTE

If built-in battery of cycle computer isn't charged sufficiently, the power will not turn on.  
The built-in battery of the cycle computer is charged only when the cycle computer screen is on.

### Turning the power ON and OFF via the battery

BT-E8010

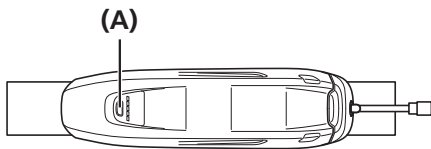

Press the power button on the battery.

The LED lamps will light up indicating remaining battery capacity.

(A) Power button

#### NOTE

- When turning on the power, check that the battery is firmly attached to the holder.
- Power cannot be turned on while charging.
- Do not place your foot on the pedals when turning on.  
A system error may result.

BT-E8020

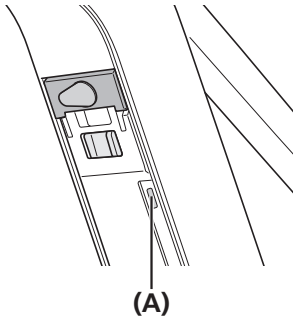

#### TECH TIPS

- To force power off, hold down the power button for 6 seconds.
- If the bicycle has not moved for over 10 minutes, the power will automatically turn off. (Automatic power off function)

# Chapter5 HOW TO OPERATE

# HOW TO OPERATE

## About the functions of the assist switches and shift switches

The following explains the operation procedure for cases where the switch settings are set to the default values.

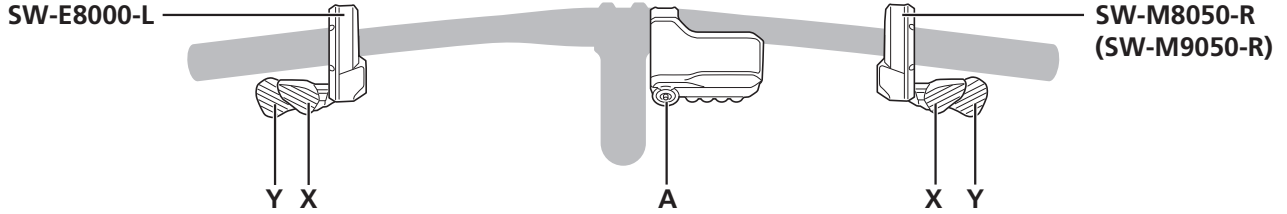

SW-E8000-L		SW-M8050-R (SW-M9050-R)	
X	Switching assist modes: the level of assistance becomes stronger	X	Shifting gears: pedaling becomes heavier
Y	Switching assist modes: the level of assistance becomes weaker	Y	Shifting gears: pedaling becomes lighter
A	Changing the cycle computer display		

< SW-E6010 >

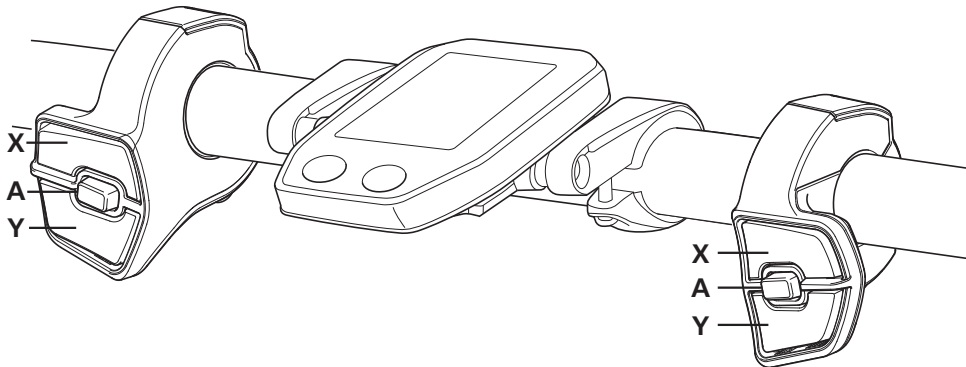

A	Changing the cycle computer display Switching between automatic and manual gear shifting
X	When switching assist modes: the level of assistance becomes stronger When shifting gears: pedaling becomes heavier
Y	When switching assist modes: the level of assistance becomes weaker When shifting gears: pedaling becomes lighter

## ■ Cycle computer display and setting

### Basic screen display of the cycle computer

SC-E8000

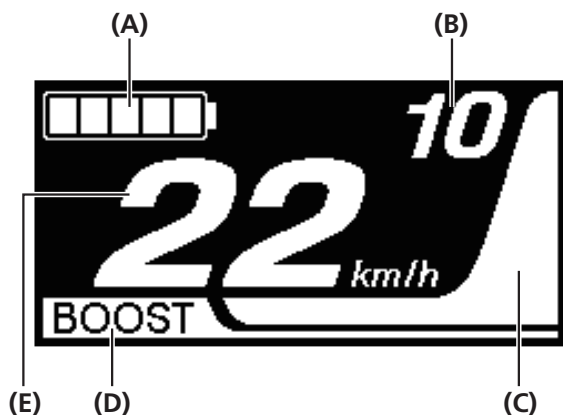



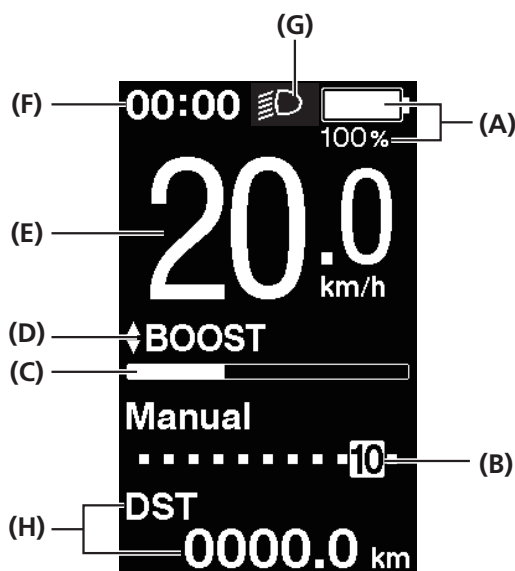



SC-E6010







- (A) Battery level indicator**  
Displays the current battery level.
- (B) Gear position (Only displays when electronic gear shifting is in use)**  
Displays the currently set gear position.
- (C) Assist gauge**  
Displays the assistance.
- (D) Assist mode display**  
Displays the current assist mode. (Assist mode automatically switches to [ECO] as remaining battery capacity declines. The switch to [ECO] occurs earlier if a battery - powered light is connected.)
- (E) Current speed**  
Displays the current speed. The display can be switched between km/h and mph.
- (F) Current time**  
Shows the current time.
- (G) Icon to indicate when the light is on**  
Notifies you when the battery-powered light is on.
- (H) Traveling data display**  
Displays the current traveling data.

## Battery level indicator

### SC-E8000

Display	Battery level
	81 - 100%
	61 - 80%
	41 - 60%
	21 - 40%
	1 - 20% *
	0%

### SC-E6010

Display	Battery level
	100%
	
	0%

Displays the current battery level by level icon and percentage.

### (A) Battery level indicator



\* The battery level indicator blinks red when remaining battery capacity falls to this level.

■ Assist mode

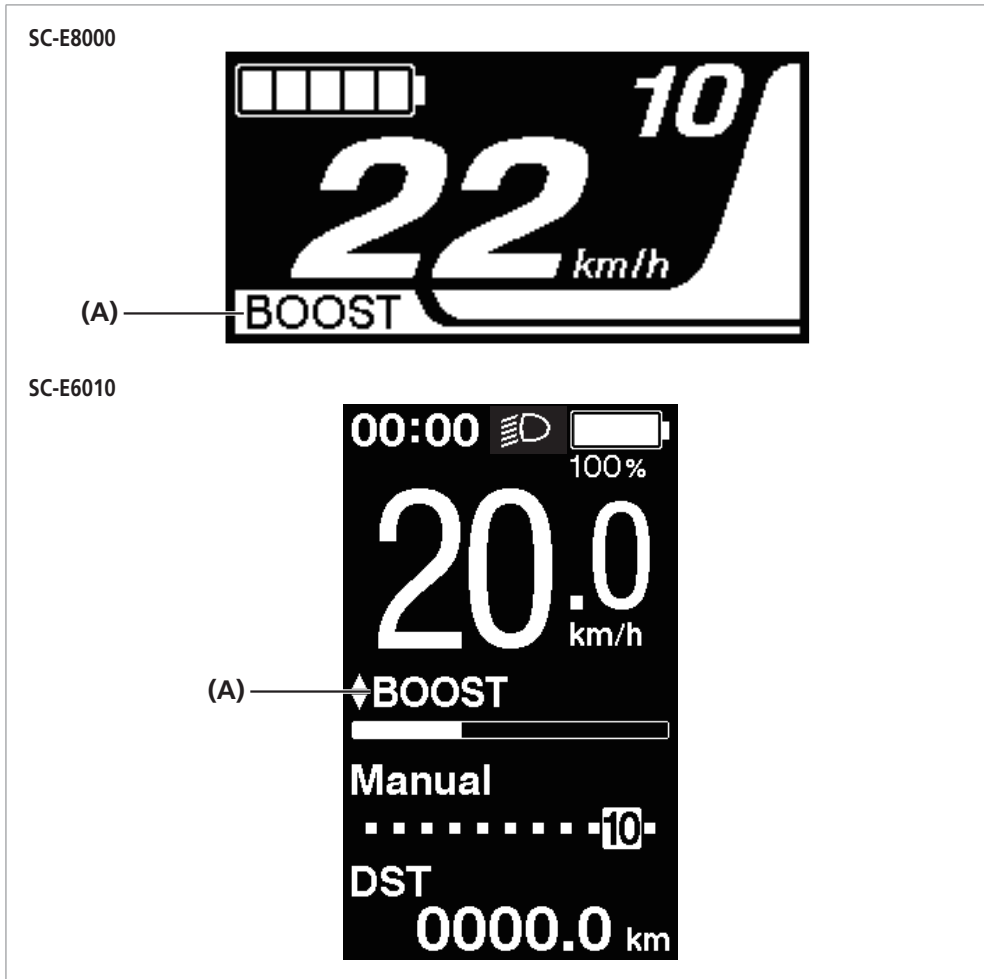

(A) Assist mode display

Changing assist mode

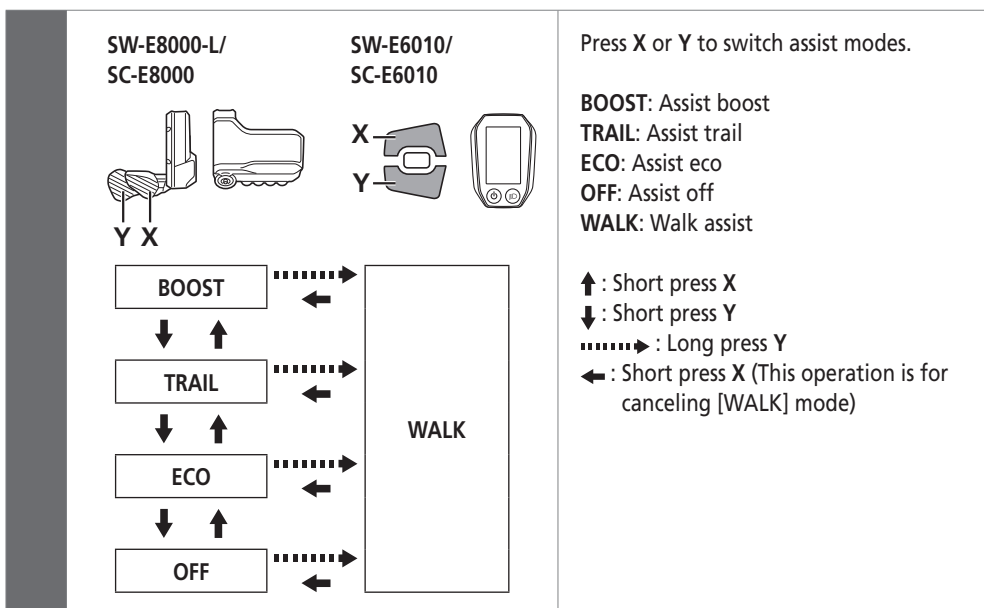

**NOTE**

The Walk assist mode function may not be able to be used in certain regions.

## Switching to [WALK] mode (walk assist mode)

SW-E8000-L/  
SC-E8000

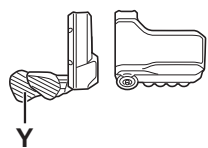

SW-E6010/  
SC-E6010

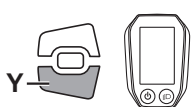

With your feet off the pedals and current speed at [0 km/h], hold down Y until [WALK] displays.

SC-E8000



SC-E6010

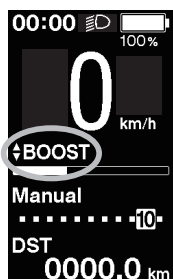

1

2

Release Y when [WALK] displays.

3

Hold down Y again to activate walk assist.  
• Walk assist remains active provided Y is being held down.

4

To cancel [WALK] mode, release Y and press X.  
• When [WALK] mode is canceled, the mode active before [WALK] mode was set, is re-activated.

### NOTE

- The Walk assist mode function may not be able to be used in certain regions.
- A warning tone will sound while switching is in progress if it is not possible to switch to [WALK] mode because the current speed is not [0 km/h] or there is pressure on the pedals etc.



### TECH TIPS

- If Y is not pressed for one minute or more, the mode active before [WALK] mode was set, is re-activated.
- If the bicycle is not moved after [WALK] mode is activated, walk assist is automatically inactivated. To re-activate [WALK] mode, momentarily release Y and then hold down Y.
- The walk assist function can operate at a maximum of 6 km/h.
- The assistance level and speed vary with the gear position.
- The intelligent walk assist function activates when an electric shifting system such as XTR, DEORE XT SEIS is connected. System individually supplies assist power to detect gear position. "Intelligent walk assist" support rider more torque output in steep climb condition in lower side gears. "Quick walk assist" function works quickly by holding down SW from any mode.

## Switching between displayed traveling data

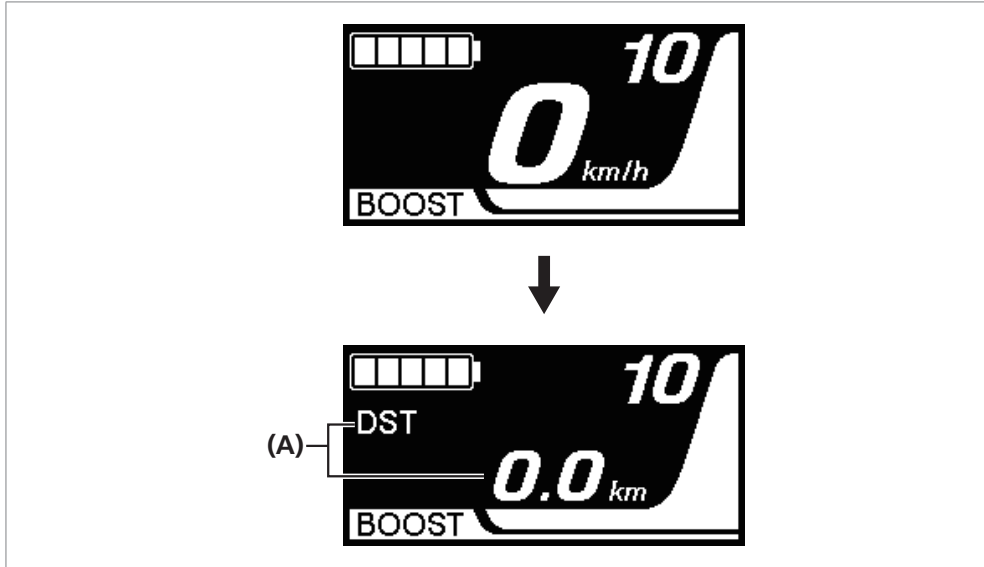

(A) Traveling data display

SW-E8000-L/  
SC-E8000

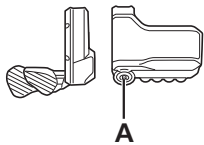

SW-E6010/  
SC-E6010

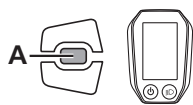

The type of traveling data displayed changes each time you press A.

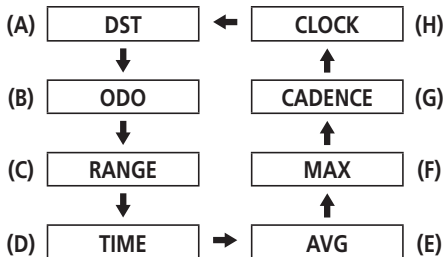

- (A) Traveling distance
- (B) Cumulative distance
- (C) Maximum traveling distance \*1, 3
- (D) Traveling time (optional) \*2
- (E) Average speed (optional) \*2
- (F) Maximum speed (optional) \*2
- (G) Number of crank rotations \*2
- (H) Current time

\*1 When [RANGE] is displayed, the battery level is not displayed. The traveling range should be used as a reference only.

\*2 Optional item: You can configure the display settings in E-TUBE PROJECT. For details, refer to "CONNECTION AND COMMUNICATION WITH DEVICES" - "Settings customizable in E-TUBE PROJECT".

\*3 When walk assistance is functioning, the on screen display [RANGE] changes to [RANGE ---].

### NOTE

- The Walk assist mode function may not be able to be used in certain regions.
- When traveling data is displayed, the screen returns to speed display after 60 seconds. When speed data is displayed, pressing A changes the traveling data displayed starting with [DST].



Holding down A when DST is displayed clears all traveling data.

## Clearing the traveling distance

You can clear the traveling distance in the main screen.

**1** Change the traveling data display to [DST] and press **A** for 2 seconds.

Release the finger when the [DST] indication starts blinking.

**2** In this state, pressing **A** again clears the traveling distance.



### TECH TIPS

- The [DST] indicator light stops blinking and the screen takes you back to the basic screen after leaving it alone for 5 seconds.
- When the traveling distance is cleared, [TIME], [AVG] and [MAX] are also cleared.

## About the setting menus

### Accessing the setting menu (SW-E8000-L/SC-E8000)

Hold down A when the bicycle is not moving to display the menu list screen.

1

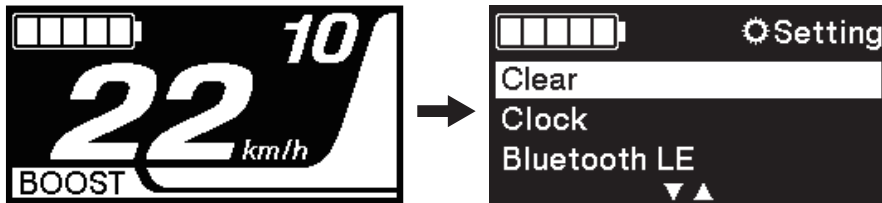
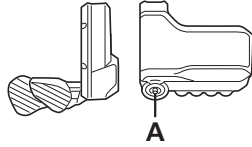

Press X or Y to select the various menus.

Press A to display the setting screen for the selected menu.

2

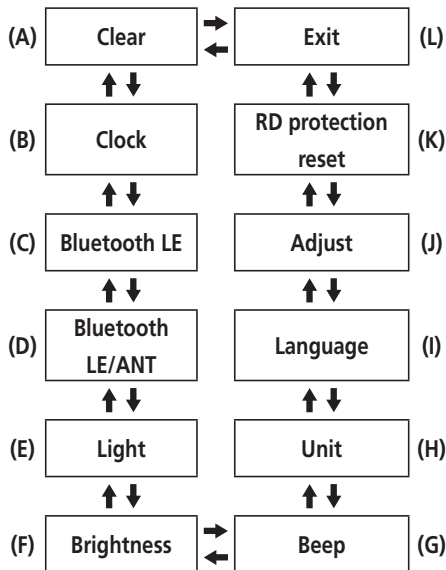
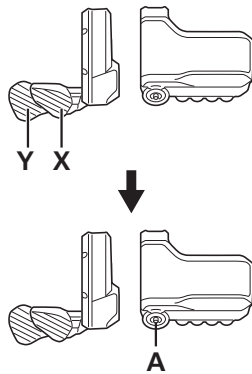

- (A) Clear settings
- (B) Clock setting
- (C) Bluetooth LE pairing
- (D) Bluetooth LE/ANT connection status
- (E) Turning the light on/off
- (F) Display backlight brightness setting
- (G) Turning the beep noise on/off
- (H) Switching between km and miles
- (I) Language setting
- (J) Adjusting the electronic gear shifting unit
- (K) Activating RD Protection Reset\*
- (L) Return to the main screen



\* In order to protect the system from falling down etc., if the bicycle is subjected to a strong impact, the RD Protection function will operate and the connection between the motor and the link will be momentarily severed so that the rear derailleur can no longer operate. Executing RD Protection Reset restores the connection between the motor and the link, as well as the function of the rear derailleur.

Accessing the setting menu (SW-E6000/SW-E6010/SC-E6010)

Hold down X and Y when the bicycle is not moving to display the menu list screen.

1

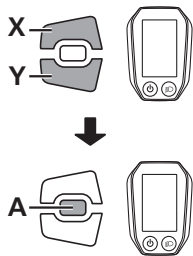
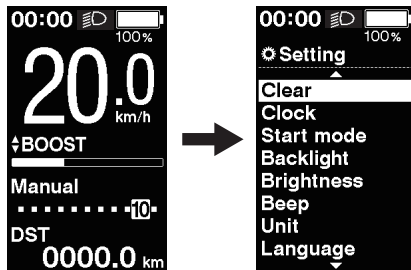
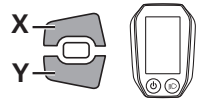

Press X or Y to select the various menus. Press A to display the setting screen for the selected menu.

[Start mode] and [Auto] are displayed on the menu list screen; however, they are not available for use.

2

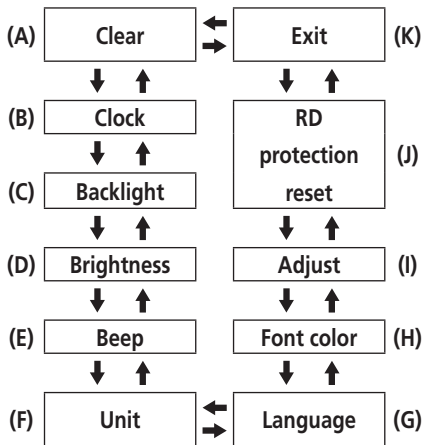

- (A) Clear settings
- (B) Clock setting
- (C) Turning the display backlight on/off
- (D) Display backlight brightness setting
- (E) Turning the beep noise on/off
- (F) Switching between km and miles
- (G) Language setting
- (H) Changing the font color
- (I) Adjusting the electronic gear shifting unit
- (J) Activating RD Protection Reset\*
- (K) Return to the main screen

TECH TIPS

\* In order to protect the system from falling down etc., if the bicycle is subjected to a strong impact, the RD Protection function will operate and the connection between the motor and the link will be momentarily severed so that the rear derailleur can no longer operate. Executing RD Protection Reset restores the connection between the motor and the link, as well as the function of the rear derailleur.

# Clear

Reset the traveling distance to default.

**SW-E8000-L/  
SC-E8000**

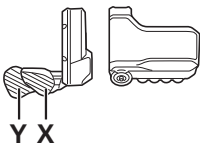

**SW-E6010/  
SC-E6010**

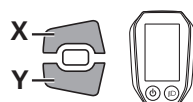

**SC-E8000**



**SC-E6010**



Press X or Y to select [DST].



**SC-E8000/SC-E6010**

Configurable items	Details
Exit	Return to the menu list screen
DST	Clearing the traveling distance

**SC-E6010**  
Default value set in the SC display setting

Configurable items	Default value
Backlight	ON
Beep	ON
Unit	km
Language	English
Brightness	3
Font color	White

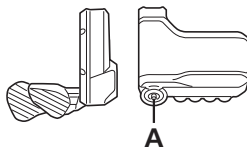
**2**

To reset traveling distance, select [OK] using X or Y and press A to confirm.

After resetting, the screen will automatically return to the menu list screen.



A reset confirmation screen is not displayed on SC-E6010.

## TECH TIPS

When the traveling distance is cleared, [TIME], [AVG] and [MAX] are also cleared.

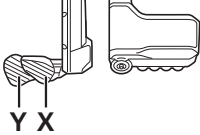
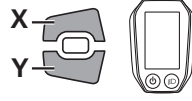

# Clock

Configure the Clock setting.

1	<p>SW-E8000-L/ SC-E8000</p> 	<p>SW-E6010/ SC-E6010</p> 	<p>Press X or Y to adjust the time.</p>
			

 **TECH TIPS**

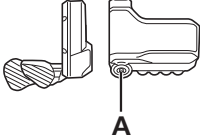
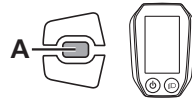
Press X to increase the numbers.  
Press Y to decrease the numbers.

2	<p>SW-E8000-L/ SC-E8000</p> 	<p>SW-E6010/ SC-E6010</p> 	<p>Pressing A enables the set value and moves you to the minutes setting.</p>
			

3	<p>Press X or Y to set the minutes.</p>
---	---

4	<p>Pressing A enables the set value and takes you back to the Setting menu screen.</p>
---	--

 **TECH TIPS**

You can change the numbers quickly by holding down X or Y.

## Bluetooth LE (SC-E8000)

E-TUBE PROJECT for smartphones/tablets may be used if a Bluetooth LE connection is established with a smartphone/tablet.

**1** Before setting up a connection, turn on Bluetooth LE on the smartphone/tablet.

**2** Open E-TUBE PROJECT and set it to listen for Bluetooth LE signals.

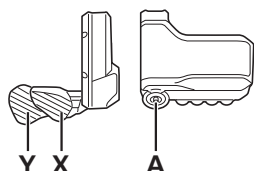

**3**

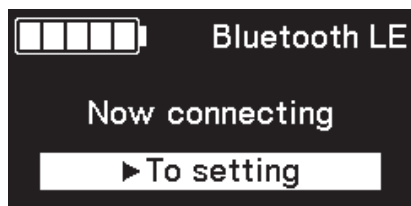

Press **X** or **Y** to select [Start].

To start Bluetooth LE pairing, press **A** to confirm.

If you press **A** during Bluetooth LE pairing, the transmission will be interrupted, then the screen will return to the menu list screen.

Item	Details
<b>Start</b>	Starts Bluetooth LE pairing
<b>Cancel</b>	To not perform pairing, select [Cancel]



Generally, Bluetooth LE transmission will begin automatically when the cycle computer is turned on, however, pairing can be started by selecting [Start] from the [Bluetooth LE] menu when connectivity is poor.

**4**



(y)



(z)

When connection is successful, SHIMANO STEPS logo is displayed on screen.

If connection is not successful, a message indicating this is displayed.

After successful connection or a connection failure, press one of **X/Y/A** or the screen will automatically return to the setting menu after awhile.

(y) Connection successful

(z) Connection failed



▶▶ About the setting menus

**5** When connection is successful, the unit name will display in E-TUBE PROJECT.

**6** Select the unit name displayed on screen.  
To disconnect, cancel the Bluetooth LE connection from the smartphone/tablet. (The cycle computer will exit connection mode and return to regular operation mode.)

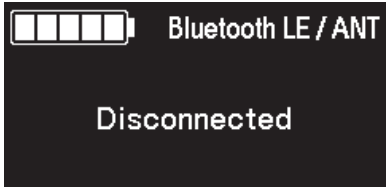
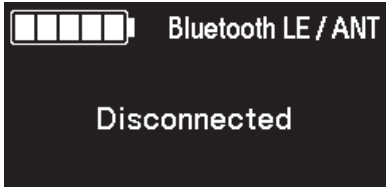

## Bluetooth LE/ANT (SC-E8000)

Current status of wireless connections can be displayed on screen.  
 For details on ANT connection, refer to "ANT connection" in the section "About wireless functions".

	Select [Bluetooth LE/ANT] from the menu list screen and confirm to display current wireless connection status.
(x) 	(x) When connected via Bluetooth LE
(y) 	(y) When an ANT signal is being emitted
(z) 	(z) When neither Bluetooth LE nor ANT is connected

## Light (SC-E8000)

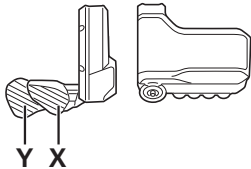
Configure the battery-powered light setting.

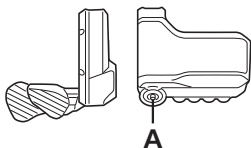
<p><b>1</b></p>  	Press X or Y to select the required setting. <table border="1" data-bbox="651 1420 1050 1563"> <thead> <tr> <th>Item</th> <th>Details</th> </tr> </thead> <tbody> <tr> <td>ON</td> <td>Keep light always on</td> </tr> <tr> <td>OFF</td> <td>Keep light always off</td> </tr> </tbody> </table>	Item	Details	ON	Keep light always on	OFF	Keep light always off
Item	Details						
ON	Keep light always on						
OFF	Keep light always off						
<p><b>2</b></p> 	Press A to confirm the setting. <ul style="list-style-type: none"> <li>After confirmation, the screen will automatically return to the menu list screen.</li> </ul>						

## Turning the battery-powered light ON or OFF (SC-E6010)

When the battery-powered light is connected, push the light button on the cycle computer to turn the light on. An icon indicating that the light is on appears on the screen. Push the button again to turn the light off. Once the light is turned off, the icon on the screen disappears.

\* When the battery powered light is not connected and [Backlight] is set to [MANUAL], pressing the light button turns the cycle computer's backlight on and off.

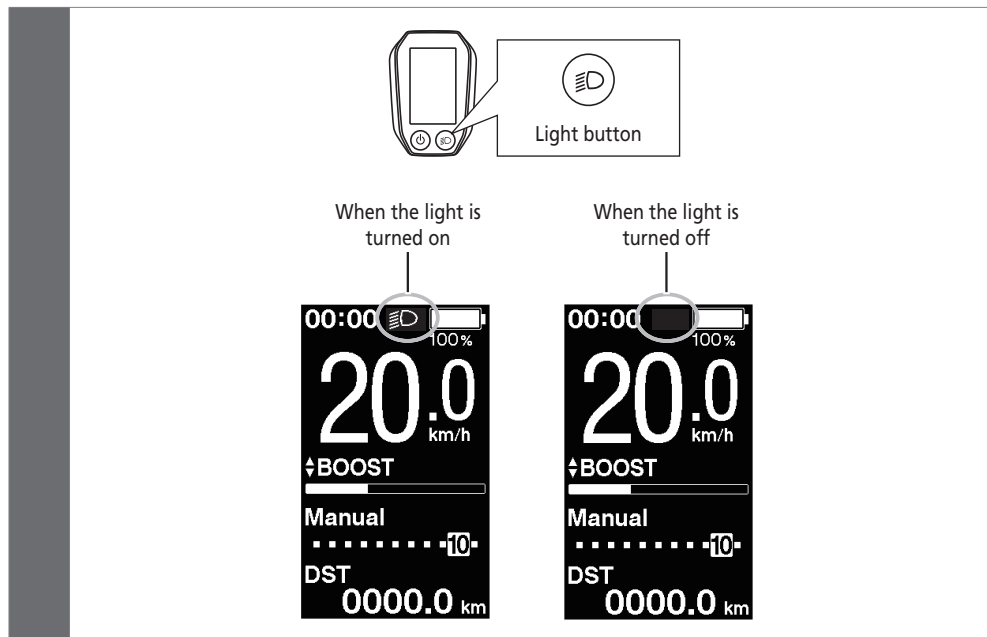

### TECH TIPS

The light turns off in conjunction with the battery power.  
When the battery power is off, the light is off.

## Backlight (SC-E6010)

Configure the display backlight setting.

**1**

SW-E6010/SC-E6010

Press X or Y to select the required setting.

Configurable items	Details
ON	Keep light always on
OFF	Keep light always off
MANUAL	Turns on and off in conjunction with the battery-powered light

**2**

SW-E6010/SC-E6010

Press A to confirm the setting.

- After confirmation, the screen will automatically return to the menu list screen.

## Brightness

The brightness of the backlight can be adjusted as needed.

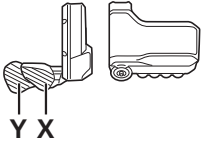
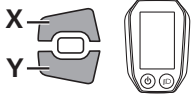
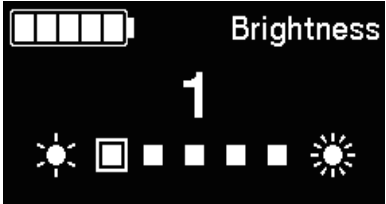
<b>1</b>	<b>SW-E8000-L/ SC-E8000</b>	<b>SW-E6010/ SC-E6010</b>	Press X or Y to adjust the brightness.
			
			

 **TECH TIPS**

---

The brightness can be adjusted in 5 levels.

---

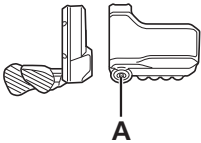
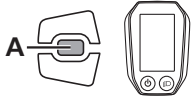
<b>2</b>	<b>SW-E8000-L/ SC-E8000</b>	<b>SW-E6010/ SC-E6010</b>	Press A to confirm the adjusted value. <ul style="list-style-type: none"><li>• After confirmation, the screen will automatically return to the menu list screen.</li></ul>
			

# Beep

The beep noise can be turned on/off.

1

SW-E8000-L/  
SC-E8000

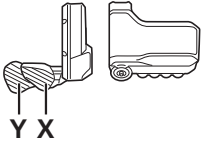

Y X

SW-E6010/  
SC-E6010

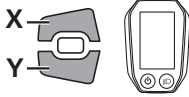

X Y



Press X or Y to select the required setting.

Item	Details
<b>ON</b>	Enable beeps
<b>OFF</b>	Disable beeps



**TECH TIPS**

---

Even when [Beep] is set to [OFF], a beep will sound when there is a misoperation, system error, etc.

2

SW-E8000-L/  
SC-E8000

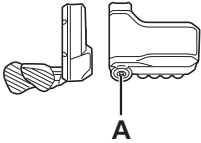

A

SW-E6010/  
SC-E6010

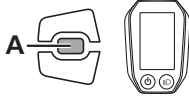

A

Press A to confirm the setting.

- After confirmation, the screen will automatically return to the menu list screen.

## Unit

Distance units (km/miles) can be switched.

1

SW-E8000-L/  
SC-E8000

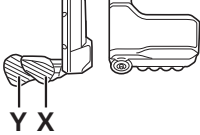

SW-E6010/  
SC-E6010

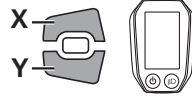

Press X or Y to select the required setting.

Item	Details
<b>km</b>	Displayed in km
<b>mile</b>	Displayed in miles



2

SW-E8000-L/  
SC-E8000

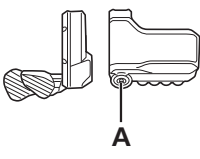

SW-E6010/  
SC-E6010

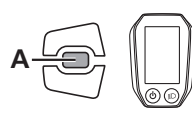

Press A to confirm the setting.

- After confirmation, the screen will automatically return to the menu list screen.

## Language

Configure the language setting.

1

SW-E8000-L/  
SC-E8000

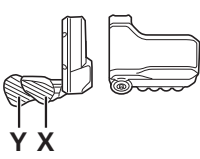

SW-E6010/  
SC-E6010

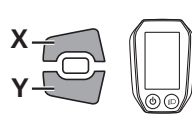

Press X or Y to select the required setting.

Language
English
French
German
Dutch
Italian
Spanish

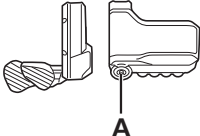
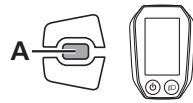

▶ About the setting menus

2	<p>SW-E8000-L/ SC-E8000</p> 	<p>SW-E6010/ SC-E6010</p> 	<p>Press <b>A</b> to confirm the setting.</p> <ul style="list-style-type: none"> <li>• After confirmation, the screen will automatically return to the menu list screen.</li> </ul>
---	---	---	---

## Font color (SC-E6010)

The font color can be changed.

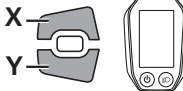
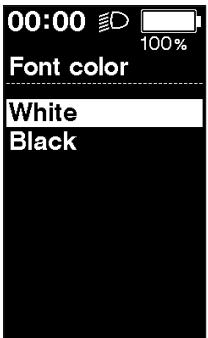
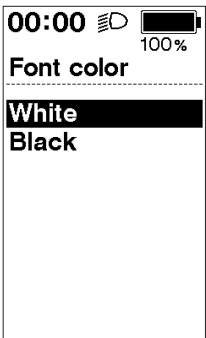
1	<p>SW-E6010/SC-E6010</p> 	<p>Press <b>X</b> or <b>Y</b> to select the required setting.</p> <table border="1" style="margin-left: auto; margin-right: auto;"> <thead> <tr> <th style="background-color: #cccccc;">Configurable items</th> </tr> </thead> <tbody> <tr> <td>White</td> </tr> <tr> <td>Black</td> </tr> </tbody> </table>	Configurable items	White	Black
	Configurable items				
White					
Black					
<div style="display: flex; justify-content: space-around;"> <div style="text-align: center;"> <p>White</p>  </div> <div style="text-align: center;"> <p>Black</p>  </div> </div>					

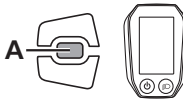
2	<p>SW-E6010/SC-E6010</p> 	<p>Press <b>A</b> to confirm the setting.</p> <ul style="list-style-type: none"> <li>• After confirmation, the screen will automatically return to the menu list screen.</li> </ul>
---	--	---

## Adjust

Gear shifting adjustment is performed with the electronic gear shifting unit.

### ⚠ CAUTION

- Improperly large adjustment may cause free spinning of the pedals during pedaling, resulting in an accidental fall.
- Perform adjustment only when gear shifting feels unusual. Under normal conditions, performing unnecessary adjustment may worsen gear shifting performance.

< SC-E8000 >

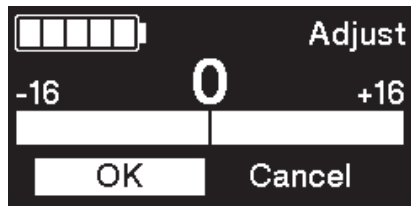

Open the Adjust screen and check whether the adjustment value is set to [0].

< SC-E6010 >

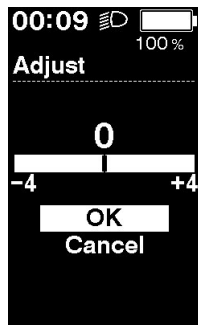

### 📖 TECH TIPS

- Gear shifting adjustment can only be performed when an electronic gear shifting unit is connected.
- The settings have a range of -16 to 16 (SC-E8000)/-4 to 4 (SC-E6010).

If the adjustment value is [0]

< SC-E8000 >

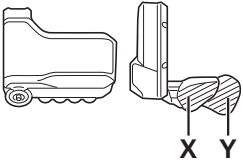

< SW-E6010 >

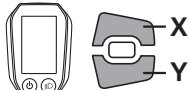

1

< SC-E8000 >



< SC-E6010 >

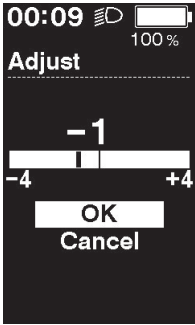

Press X or Y to adjust the adjustment value up or down by 1 speed.

< SC-E8000 >

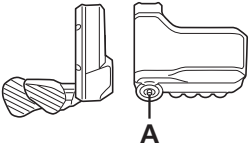

< SW-E6010 >

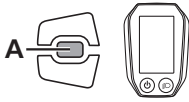

2



Press A and after selecting [OK], adjust by rotating the crank.

Shift gears to check whether the condition has improved.

### The condition has improved

Adjust the adjustment value by 1 speed in the same direction and check the gear shifting operation again.

Repeat these steps until any noise or unusual feeling disappears.

3

< SC-E8000 >

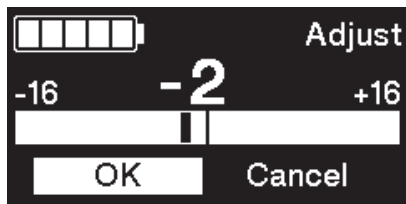
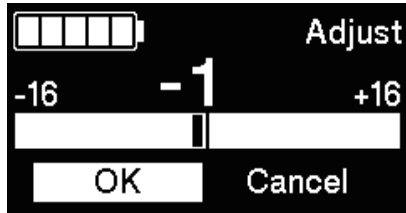

< SC-E6010 >

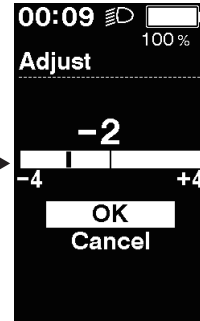
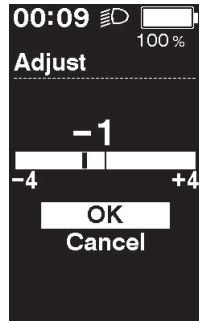

### No apparent change

Adjust the adjustment value by 1 speed in the same direction and check the gear shifting operation again.

If the condition has improved, see "The condition has improved" to continue.

If the condition has worsened, see "The condition has worsened" to continue.

3

< SC-E8000 >

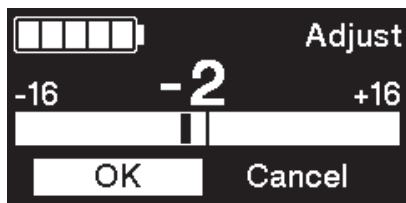
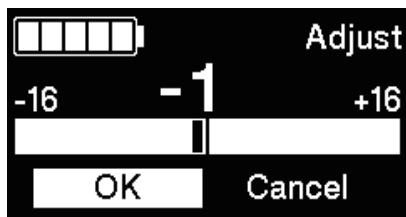

< SC-E6010 >

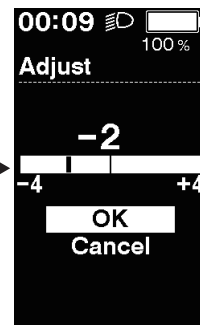
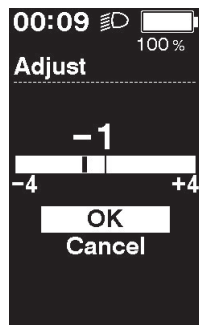

### The condition has worsened

Adjust the adjustment value by 2 speeds in the opposite direction and check the gear shifting operation again.

Then, adjust the value by 1 speed in the same direction and check until any noise or unusual feeling is gone.

3

< SC-E8000 >

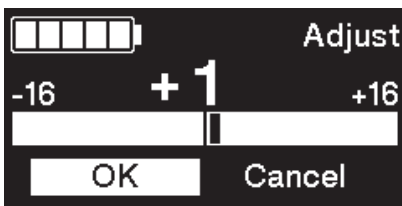
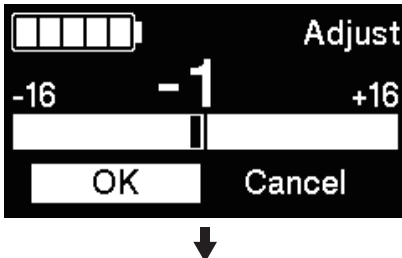

< SC-E6010 >

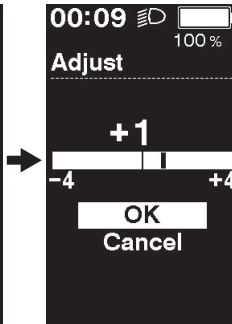
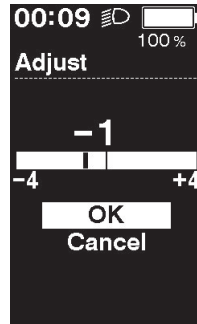

4

Finally, go for an actual ride and check for any noise or unusual feeling.

### If the adjustment value is not [0]

Press X or Y and revert the adjustment value to [0].

< SC-E8000 >

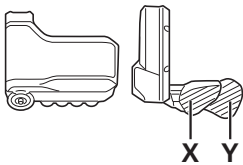

< SW-E6010 >

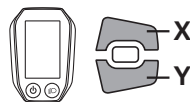

1

< SC-E8000 >

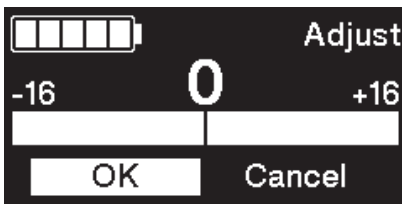
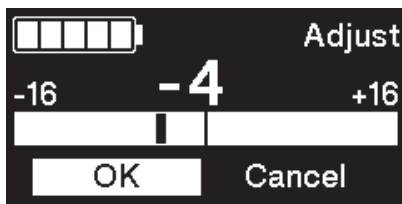

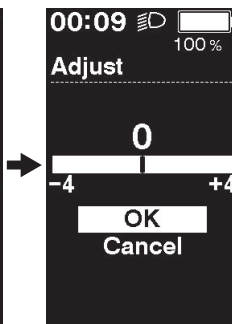
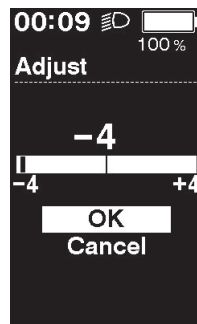

< SC-E6010 >



About the setting menus

**2**

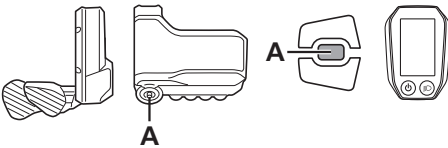
< SC-E8000 >      < SW-E6010 >

Press **A** and after selecting [OK], adjust by rotating the crank.

Shift gears to check whether the condition has improved.

If there is any noise or unusual feeling, see "If the adjustment value is [0]" to continue.

**3** Finally, go for an actual ride and check for any noise or unusual feeling.

**RD protection reset**

In order to protect the system from falls etc., if the bicycle is subjected to a strong impact, the RD Protection function will operate and the connection between the motor and the link will be momentarily severed so that the rear derailleur can no longer operate. Executing RD Protection Reset restores the connection between the motor and the link, as well as the function of the rear derailleur.

**1**

SW-E8000-L/  
SC-E8000      SW-E6010/  
SC-E6010

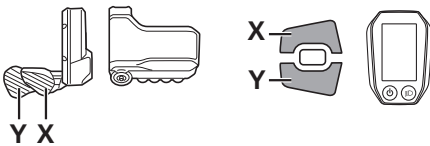
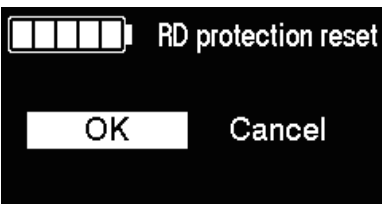



Press **X** or **Y** to select [OK].

Item	Details
OK	RD Protection Reset will operate
Cancel	To not execute RD Protection Reset, select [Cancel]

**2**

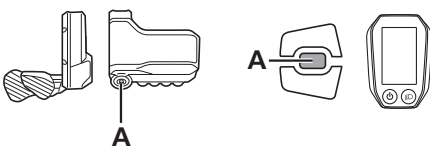
SW-E8000-L/  
SC-E8000      SW-E6010/  
SC-E6010

Press **A** and after selecting [OK], recover the connection between the motor and the link by rotating the crank.

## Exit

Closes the menu list screen and returns to the basic screen.

**1** Press X or Y to select [Exit] on the menu list screen.

**2** Press A to confirm. After confirmation, the screen will return to the basic screen.

## Update confirmation window for the drive unit settings backup data

The cycle computer has a function to automatically back up drive unit settings.

In the following cases, when the cycle computer power is turned on, a window confirming whether to update the backup data is displayed:

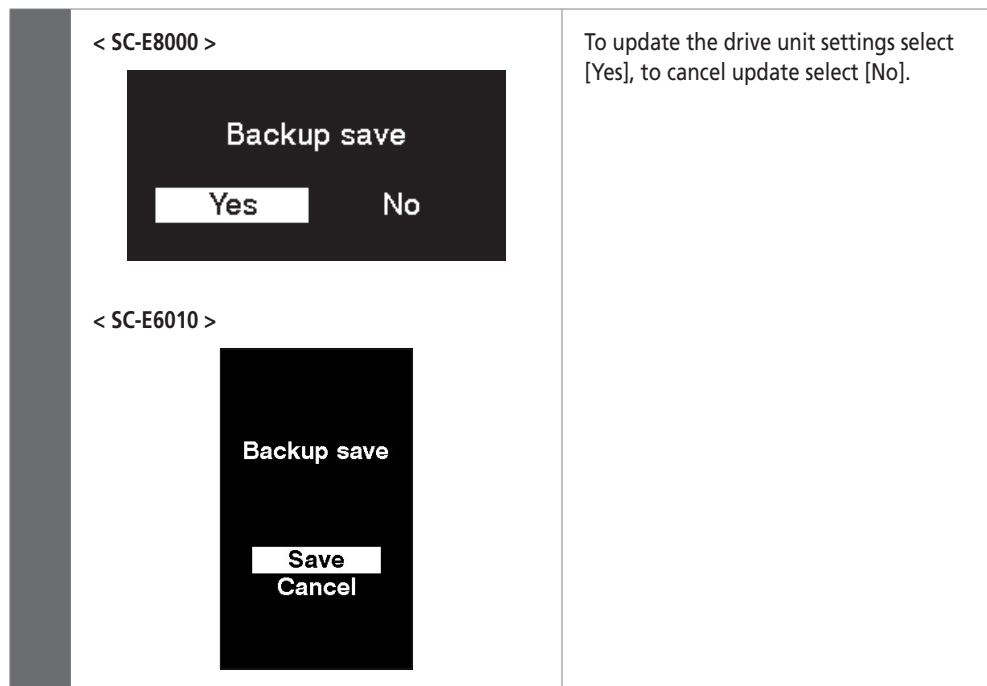

- Reinstalling the cycle computer on a bicycle with different settings
- If the drive unit settings have been changed via E-TUBE PROJECT



If the settings cannot be accessed due to a drive unit malfunction, they can be accessed using E-TUBE PROJECT.

## ■ Error messages on the cycle computer

### Warnings

<p>&lt; SC-E8000 &gt;</p> 	<p>This disappears if the error is fixed.</p>
<p>&lt; SC-E6010 &gt;</p> 	

### List of warnings

Code	Display preconditions	Operational restrictions while warning is displayed	Remedy
W010	Temperature of the drive unit is higher than it is during times of normal operation.	Power assistance may be lower than usual.	Stop using the assist function until the temperature of the drive unit drops. If the situation does not improve, consult an agency.
W011	The traveling speed cannot be detected.	The maximum speed up to which power assistance is provided may be lower than usual.	Check that the speed sensor is properly installed. If the situation does not improve, consult an agency.
W013	Initialization of torque sensor was not completed successfully.	Power assistance may be lower than usual.	With your foot off the pedal, press the battery power button and turn on the power again. If the situation does not improve, contact the place of purchase.
W032	An electronic derailleur may have been installed in place of a mechanical derailleur.	Power assistance provided in [WALK] mode may be lower than usual. * The Walk assist mode function may not be able to be used in certain regions.	Reinstall the derailleur for which the system is configured to support. If the situation does not improve, contact the place of purchase.

## Errors

< SC-E8000 >



< SC-E6010 >



If an error message is displayed on the entire screen, follow one of the procedures below to reset the display.

- Press the power switch of the battery.
- Remove the battery from the mount.

### NOTE

If resetting does not solve the problem or the same problem occurs frequently, consult an agency.

## List of errors

Code	Display preconditions	Operational restriction when an error is being displayed	Remedy
E010	A system error was detected.	Power assistance is not provided during riding.	Press the power switch of the battery to turn on the power again. If the situation does not improve, consult an agency.
E011	An error occurred in system operation.	Power assistance is not provided during riding.	Turn on the power again.
E013	An error was detected in the drive unit's firmware.	Power assistance is not provided during riding.	Contact your place of purchase or a local bicycle dealer for assistance.
E014	The speed sensor may have been installed in the wrong position.	Power assistance is not provided during riding.	Contact your place of purchase or a local bicycle dealer for assistance.
E020	A communication error between the battery and drive unit was detected.	Power assistance is not provided during riding.	Check that the cable between the drive unit and battery is properly connected. If the situation does not improve, consult an agency.
E021	Battery connected to drive unit conforms with system standards but is not supported.	Power assistance is not provided during riding.	Press the power switch of the battery to turn on the power again. If the situation still does not improve, consult an agency.
E022	Battery connected to drive unit does not conform with system standards.	All system functions shutdown.	Press the power button of the battery to turn it on again. If the situation does not improve, contact the place of purchase.

## ▶▶ Error messages on the cycle computer

Code	Display preconditions	Operational restriction when an error is being displayed	Remedy
E033	The current firmware doesn't support system operation.	Power assistance is not provided during riding.	Connect to E-TUBE PROJECT and update firmware for all unit.
E043	The cycle computer's firmware may be partially corrupt.	Power assistance is not provided during riding.	Contact your place of purchase or a local bicycle dealer for assistance.

# **Chapter6 CONNECTION AND COMMUNICATION WITH DEVICES**

## CONNECTION AND COMMUNICATION WITH DEVICES

The system can be configured and firmware can be updated when the bicycle is connected to a device.

You need E-TUBE PROJECT to configure SHIMANO STEPS and update firmware.

Download E-TUBE PROJECT from our support website (<http://e-tubeproject.shimano.com>).

For information on how to install E-TUBE PROJECT, check the E-TUBE support website.

### NOTE

- You need SM-PCE1 and SM-JC40/JC41 to connect SHIMANO STEPS to a PC. They are not required if there is an available port.
- Firmware is subject to change without notice.
- PC connection and communication are not possible during charging.
- Connecting to devices is not possible while charging.

## ■ About wireless functions

### Functions

#### ANT connection

The wireless unit transmits the following information to the cycle computer.

- Battery level
- Front and rear derailleur gear positions
- Adjustment value



#### TECH TIPS

The latest functions can be checked by updating the software via E-TUBE PROJECT. For details, consult the place of purchase.

#### Bluetooth® LE connection

E-TUBE PROJECT for smartphones/tablets may be used if a Bluetooth LE connection is established with a smartphone/tablet.

## How to make connections

### ANT connection

ANT transmission will begin automatically when the cycle computer is turned on. To confirm whether connection was successful, check the [Bluetooth LE/ANT] menu.

### Bluetooth® LE connection

Generally, Bluetooth LE transmission will begin automatically when the cycle computer is turned on, however, pairing can be started by [Bluetooth LE] menu when connectivity is poor.

## ■ 2.4 GHz digital wireless system

2.4 GHz-frequency digital wireless technology, which is the same technology used for wireless LAN.

However, on very rare occasions, objects and places may generate strong electromagnetic, waves and interference, which may result in incorrect measurement.

- Television, PC, radios, motors/engines, or in car and trains.
- Railroad crossings and near railway tracks, around television transmitting stations and radar bases.
- Other wireless computers or digitally controlled light.

## ■ Drive unit setting backup function for the cycle computer

To check the drive unit settings backed up to the cycle computer, export the PDF report from the E-TUBE PROJECT [Unit log acquisition] menu. When exchanging the drive unit, send the report along with the unit to your place of purchase or a local bicycle dealer.

## ■ Settings customizable in E-TUBE PROJECT

< SC-E8000 >

Drive unit setting	Light connection	Sets whether to use a light.
Display monitor settings	Display units	Switches the display unit between km and mile.
	Display switchover	You can select whether to display the items Traveling time, Average speed, Maximum speed, Cadence (Number of crank rotations) and Range overview.
	Time setting	Sets the time.
	Beep setting	Switches the beep sound on or off.
	Backlight brightness setting	The backlight's brightness can be adjusted.
	Display language	You can choose from English, French, German, Dutch, Spanish, and Italian.
Other functions		<ul style="list-style-type: none"> <li>• Error check</li> <li>• Update firmware</li> <li>• Preset</li> <li>• Unit log acquisition</li> </ul> <p>* For details, download E-TUBE PROJECT and refer to the manual provided.</p>

## &lt; SC-E6010 &gt;

<b>Switch function setting</b>		Changes the functions to assign to switches A, X, and Y of SW-E6010. Functions that can be assigned vary depending on the type of switch. • The same function cannot be assigned to different switches.
<b>Switch mode setting</b>		Sets SW-E6010 to be used for either assist mode switching or gear shifting.
<b>Drive unit setting</b>	<b>Light connection</b>	Sets whether to use a light.
	<b>Start mode</b>	Switches the start mode on or off. You can change gear position when on is selected.
	<b>Automatic gear shifting</b>	Auto gear shifting can be enabled or disabled. The timing for gear shifting can also be adjusted.
<b>Display monitor settings</b>	<b>Display units</b>	Switches the display unit between km and mile.
	<b>Time setting</b>	Sets the time.
	<b>Backlight setting</b>	Switches the backlight of the cycle computer on or off.
	<b>Backlight brightness setting</b>	The backlight's brightness can be adjusted.
	<b>Beep setting</b>	Switches the beep sound on or off.
	<b>Display language</b>	You can choose from English, French, German, Dutch, Spanish, and Italian.
	<b>Font color setting</b>	The font color can be set to white or black.
	<b>Traveling time</b>	Switches the traveling time indication on or off.
	<b>Average speed</b>	Switches the average speed indication on or off.
	<b>Maximum speed</b>	Switches the maximum speed indication on or off.
<b>Range overview</b>	Switches the traveling range list indication on or off.	
<b>Motor unit gear setting</b>		Switches MU-S705 between the 8-speed and 11-speed setting.
<b>Other functions</b>		<ul style="list-style-type: none"> <li>• Error check</li> <li>• Update firmware</li> <li>• Preset</li> <li>• Unit log acquisition</li> </ul> <p>* For details, download E-TUBE PROJECT and refer to the manual provided.</p>

**NOTE**

When the SC-E6010 firmware is updated, the time set for the cycle computer is reset to match the computer's clock.

## ■ Connecting to the PC

### When connecting only individual units

Connect SM-PCE1 to the connector of each unit.

#### < SC-E8000 >

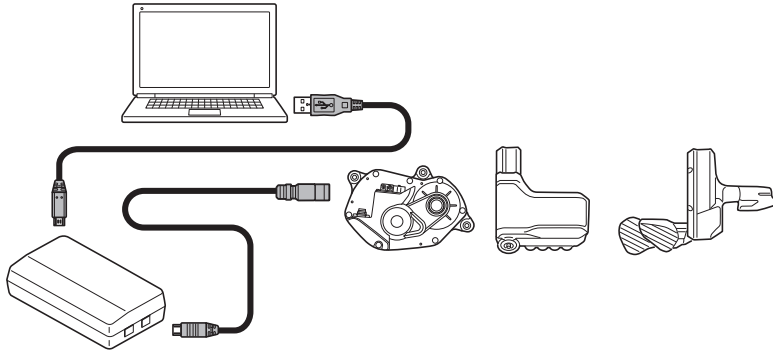

#### < SC-E6010 >

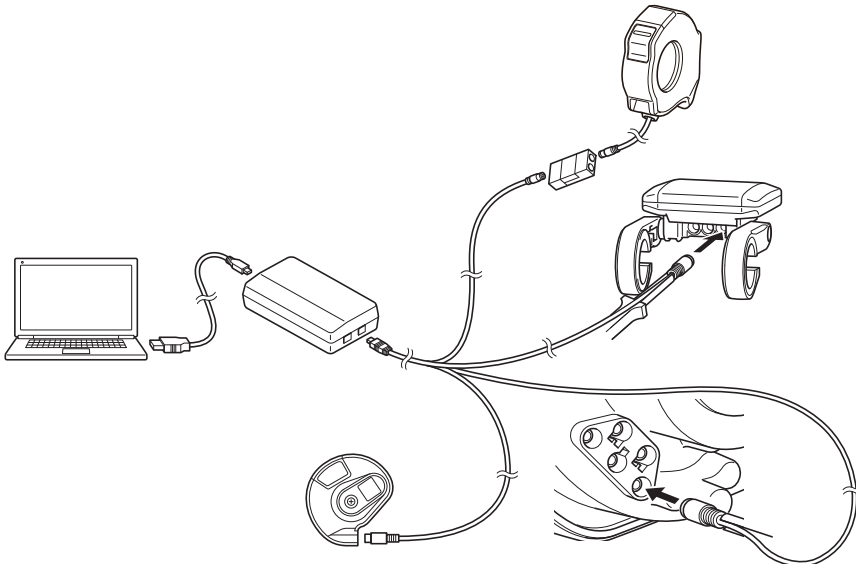

### NOTE

- When connecting only SW-E8000-L/ SW-E6010, you need SM-JC40/41.
- Individual units cannot be connected via wireless connection.

## Connecting to the bicycle

< SC-E8000 >

Connect SM-PCE1 to an available port of the cycle computer.

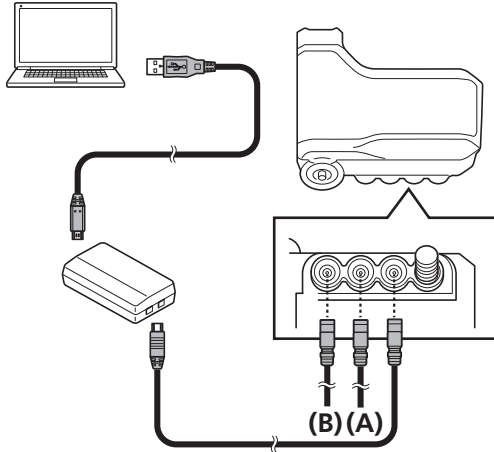

- (A) Assist switch
- (B) Drive unit

### When using electronic gear shifting

First, connect SM-JC40/JC41 to SM-PCE1.

Then, disconnect EW-SD50 from the center port of the cycle computer and connect it to SM-JC40/JC41.

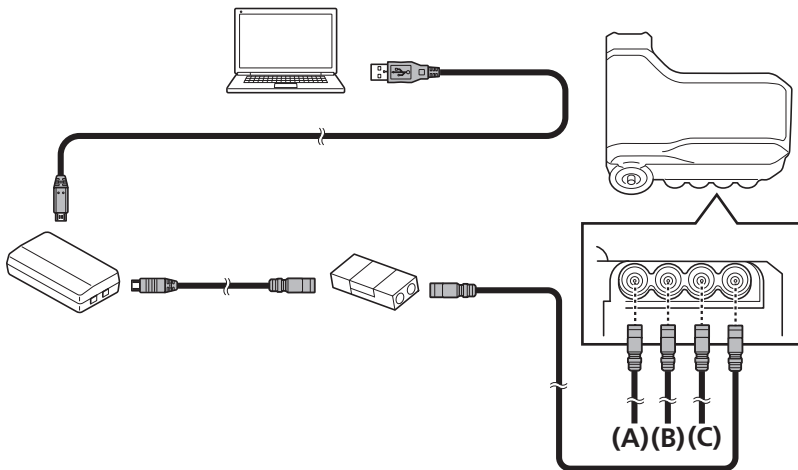

- (A) Assist switch
- (B) Drive unit
- (C) Shift switch

▶ Connecting to the PC

< SC-E6010 >

< When the cycle computer has an available port >

1

Connect SM-PCE1 to an available port of the cycle computer.

(A) Assist switch  
(B) Drive Unit

< When the cycle computer has no available port >

1

First, connect SM-JC40/JC41 to SM-PCE1.  
Then, disconnect EW-SD50 from the center port of the cycle computer and connect it to SM-JC40/JC41.

(A) Assist switch  
(B) Drive Unit

2

Connect EW-SD50 to the available port of SM-JC40/JC41 and the center port of the cycle computer.

# Chapter7 MAINTENANCE

## MAINTENANCE

### ■ Replacing the clamp band

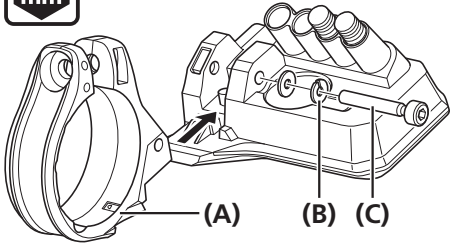

Remove the case fixing bolt with a 2.5 mm hexagon wrench and replace the clamp band.

- (A) Clamp band
- (B) Washer
- (C) Case fixing bolt

#### Tightening torque



0.6 N·m

#### NOTE

If using a handlebar with a thick diameter, reinstall it using the included  $\varnothing 35$  mm clamp band.

## ■ Replacing the front chainring

1

Perform procedures with the chain installed to the rear wheel.  
Attach the left and right crank arms using TL-FC16.

2

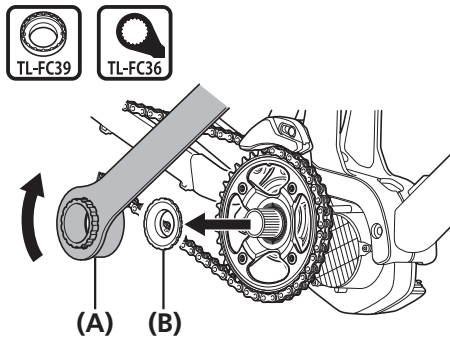

While holding the wheel, use the Shimano original tool to loosen the lock ring in the direction shown in the illustration.

- (A) TL-FC39/TL-FC36
- (B) Lock ring

### NOTE

- If using a torque wrench, use TL-FC39 in combination with TL-FC33.

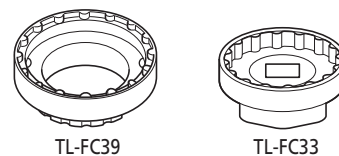

- An impact wrench cannot be used.

3

Remove and then replace the front chainring.

To install a front chainring, refer to "INSTALLING AND WIRING THE DRIVE UNIT" and "Installing the crank and front chainring".

## Replacing the chain guard (SM-CRE80 44T Double chain guard)

Replace the chain guard as shown in the illustration.

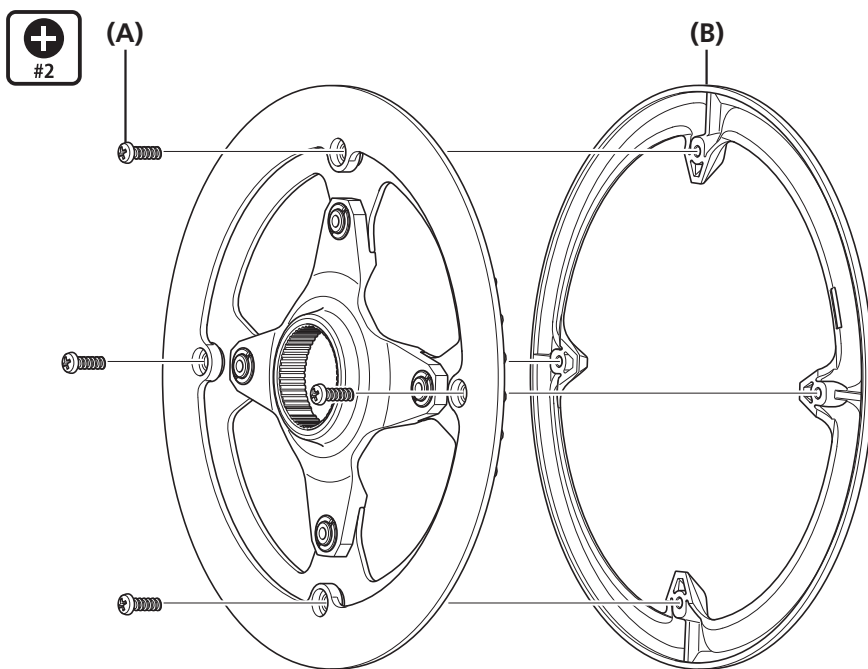

- (A) Chain guard fixing bolt
- (B) Chain guard

### Tightening torque



0.7 N·m

## ■ Replacing the guide of the chain device

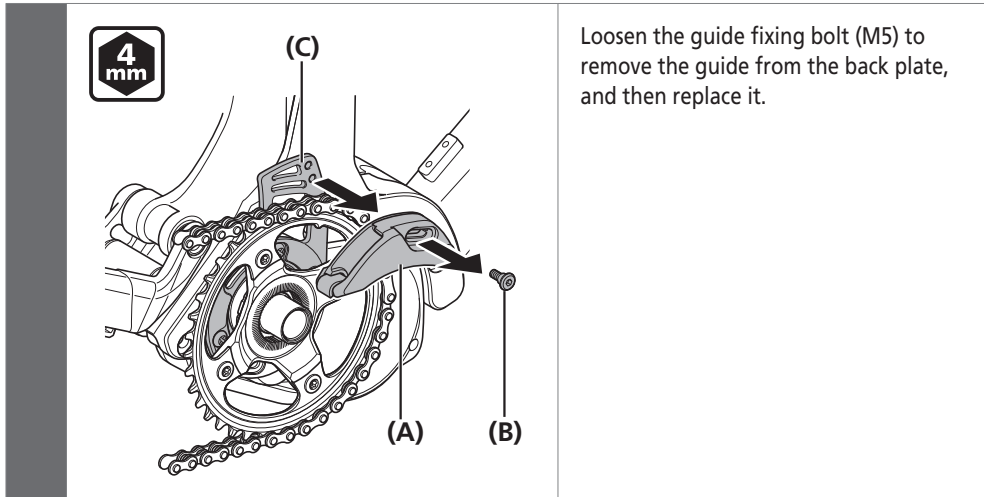

- (A) Guide
- (B) Guide fixing bolt (M5)
- (C) Back plate

### NOTE

A chain device cannot be used with SM-CRE80 (44T CL: 50 mm Double chain guard).

# SHIMANO

**SHIMANO NORTH AMERICA BICYCLE, INC.**

One Holland, Irvine, California 92618, U.S.A. Phone: +1-949-951-5003

**SHIMANO EUROPE B.V.**

High Tech Campus 92, 5656 AG Eindhoven, The Netherlands Phone: +31-402-612222

**SHIMANO INC.**

3-77 Oimatsu-cho, Sakai-ku, Sakai-shi, Osaka 590-8577, Japan

Please note: specifications are subject to change for improvement without notice. (English)

© Sep. 2017 by Shimano Inc. ITP